

Leviat[®]
A CRH COMPANY



Ancon[®]

Tension and Compression Systems

for the Construction Industry

April 2022



We are one team. **We are Leviat.**

Leviat is the new name of CRH's construction accessories companies worldwide.

Under the Leviat brand, we have united the expertise, skills and resources of Ancon and its sister companies to create a world leader in fixing, connecting and anchoring technology.

The products you know and trust will remain an integral part of Leviat's comprehensive brand and product portfolio. As Leviat, we can offer you an extended range of specialist products and services, greater technical expertise, a larger and more agile supply chain and better, faster innovation.

By bringing together CRH's construction accessories family as one global organisation, we are better equipped to meet the needs of our customers, and the demands of construction projects, of any scale, anywhere in the world.

This is an exciting change. Join us on our journey.

Read more about Leviat at [Leviat.com](https://www.leviat.com)



Our product brands include:

Ancon[®]

Connolly

HALFEN

HELIFIX

ISEDIO

PLAKA



60

locations

sales in
30+
countries

3000

people worldwide

Imagine. Model. Make.

Leviat.com

Tension and Compression Systems

Tension Rod Systems at Leviat

Tension Rod systems are increasingly being used in structures and buildings as an architectural as well as a structural element.

As a forward thinking company, Leviat is focused on the ever-changing demands of the industry. Our recent development looks to combine the Ancon and Halfen rod system portfolios to ensure the individual demands of our customers and the industry are met with a range of our market-leading construction solutions.

The product portfolio of both systems consists of different combinations of materials and finishes, with two different certifications.

Benefits of the Ancon-TS 500 SS Stainless Steel Tension Rod Systems

- ✓ UKCA & CE Marked
- ✓ High load capacity
- ✓ Project specific configurations for system diameter and length
- ✓ Visual confirmation of correct installation
- ✓ A choice of finishes; electro-, satin- or hand polished
- ✓ Suitable for static load applications



Benefits of the DETAN-S Carbon Steel Rod Systems

- ✓ European Technical Assessment
- ✓ Complete system in hot-dip galvanized including hot-dip galvanized components, brushed threads & seal-sets for maximum corrosion protection
- ✓ Additional diameters & higher load capacity for most diameters
- ✓ Project specific configurations for system diameter and length
- ✓ Complimentary design software and planning support
- ✓ Suitable for static load applications



For more information on our Ancon and Halfen Tension Rod products, contact us on:

Tel: +64 (0) 3 376 5205

Email: info.nz@leviat.com

Tension and Compression Systems

High performance in an architectural design

Tension and compression bars are increasingly being used in structures and buildings as an architectural as well as a structural element.

In addition to providing a high load capacity, our systems meet the demanding aesthetic requirements of today's applications which can range from sporting stadia roof structures to glazed areas in office developments.

Leviat manufactures a range of components that can be used to create a variety of assemblies, from simple tie bars to complex bracing systems involving several bars joined at one point. Unlike standard tie bars that require turnbuckles, adjustment to the length is accommodated within the fork connectors.

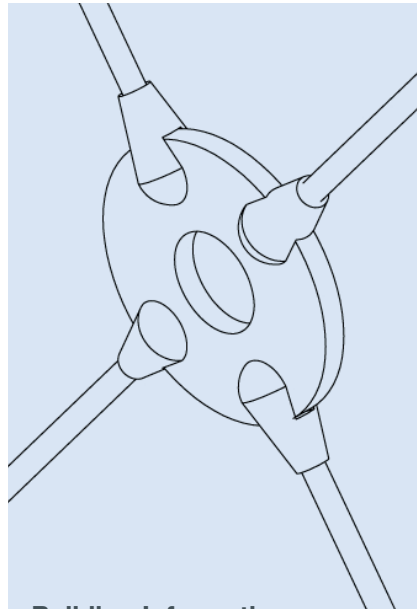

Building Information Modelling

Ancon 500 tension systems are available as BIM Objects for use in a 3D building model and its associated component database.

Visit www.ancon.com.au to download our objects in Revit, IFC, ArchiCAD, Vectorworks and Bentley file formats.

Contents

Ancon 500 Tension Systems	7-8	Connecting Plates	16
Ancon Compression Systems	8	Specifying and Ordering	16
System Components	9-10	Installation Guidance	17-18
Applications	11-12	Other Ancon Products	18
Performance and Dimensions	13-16		

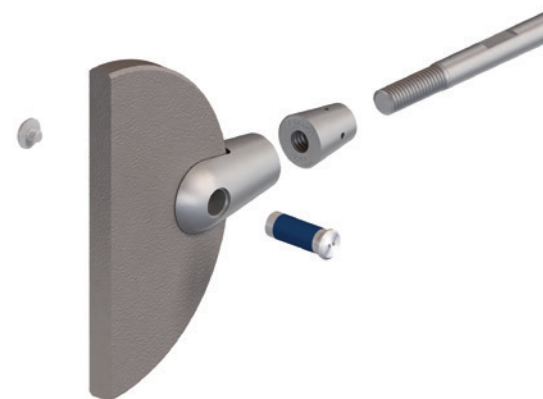



BIM objects available



Adjustment without turnbuckles



Supplied as complete systems



Large range of sizes and loads



Polished finish available



Comprehensive international project portfolio



ISO 9001 & ISO 14001

Tension and Compression Systems

Ancon 500 Tension System

The Ancon 500 Tension System combines aesthetic appearance with high performance. It is available in various sizes from 8mm to 42mm in stainless steel.

All components of the system can be supplied in a variety of finishes to provide corrosion resistance and to meet the demanding aesthetic requirements of many architectural applications. The bar used in this system has a minimum yield of 500MPa.

- ✓ High load capacity
- ✓ Stainless steel
- ✓ Bars from 8mm to 42mm diameter
- ✓ Choice of finishes
- ✓ Aesthetically designed forks
- ✓ Locking nut included as standard
- ✓ Full adjustment within fork connectors
- ✓ Visual check of correct installation
- ✓ Isolation supplied as standard with stainless steel systems

Ancon 500 Tension System Stainless Steel

The stainless steel Ancon 500 System is recommended for applications that demand corrosion resistance and a maintenance-free life, or where an attractive, polished finish is required. Stainless steel bars can be supplied in nine diameters, in most cases in lengths up to 6 metres. Performance details are shown on page 13 and the availability of each size of bar is given on page 14. The system can be extended beyond the maximum bar length by the inclusion of couplers or anchor discs. The fork connectors and couplers are designed to allow adjustments to be made to the system length without the need for turnbuckles.

Surface finish is usually an important factor in applications using stainless steel. Ancon bars are bright drawn as standard but can be hand polished if required. The stainless steel forks and locking nuts can be supplied electro-polished, satin-polished or hand polished. The photographs below provide a good indication of the available finishes; actual finishes may differ slightly. Couplers and anchor discs are supplied with a smooth machined finish as standard, and can be satin-polished or hand polished when required. All available finishes and order codes are shown on page 16.



Isolation System

Isolation material is supplied as standard with the stainless steel system to enable its fixing to a connecting plate of a dissimilar metal. Each stainless steel fork connector is supplied with two clear, self-adhesive, PET (polyester) washers to be applied around the fixing hole either side of the structure. Stainless steel pins feature a PTFE coating around the barrel.

Ancon Compression Systems

To complement the Tension System range, Leviat designs and manufactures Compression Systems. These systems use the same fork connectors and locking nuts as the Tension System but use high strength tubes instead of bars.

They are available in stainless steel in a variety of sizes and finishes. To enable us to design a compression system the following information is required:

- Pin to pin dimension
- Applied system load
- Material and surface finish

For further information on compression systems please contact us.

Electro-polished stainless steel fork and locking nut with bright drawn bar

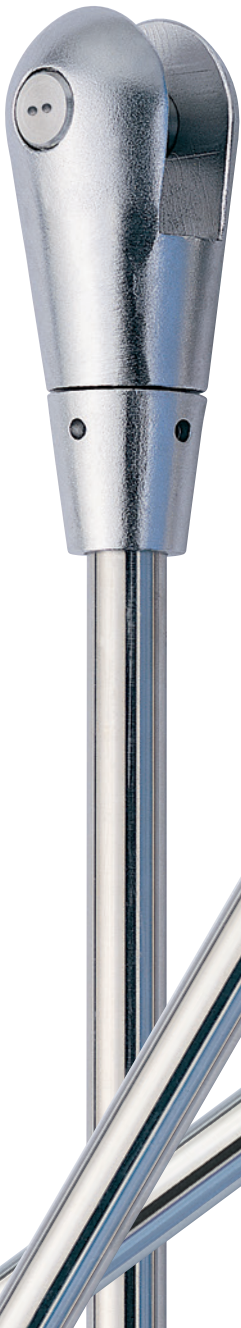

Satin-polished stainless steel fork and locking nut with bright drawn bar



Hand polished stainless steel fork, locking nut and bar



Hand polished stainless steel compression system

Tension and Compression Systems

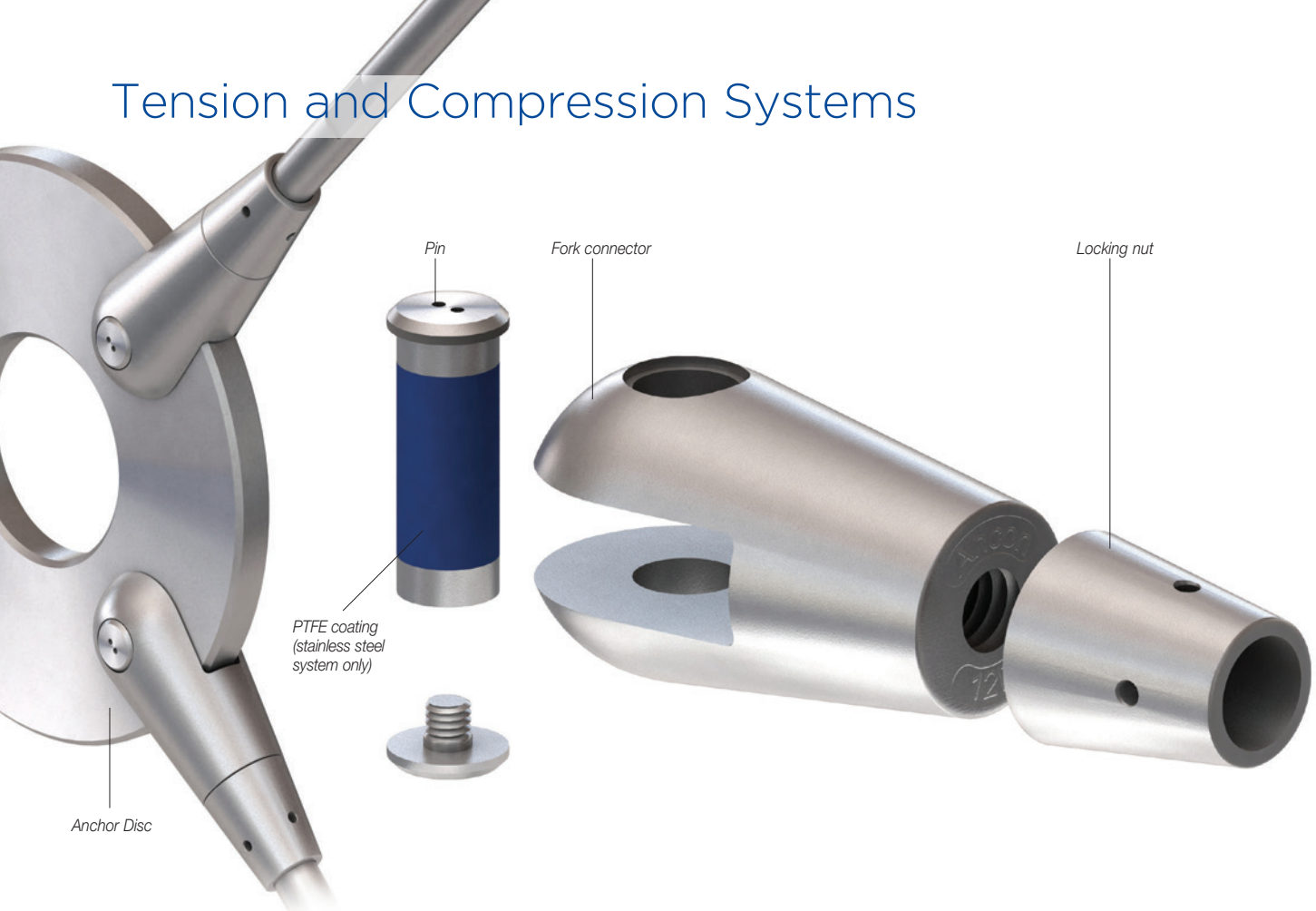

System Components

The wide range of components available can be used to create a variety of assemblies, from simple tie bars to complex bracing systems involving several bars joined at one point.

Fork Connectors & Locking Nuts

Ancon fork connectors are supplied with a locking nut which provides a neat transition from bar to fork. Forks and their locking nuts have left or right hand threads, and are supplied complete with a pin. They are stamped with the size and either the letter R or L to identify the hand of the thread.

The locking nuts firmly lock the bar to the fork and ensure that the connection remains secure. The internally threaded section of the locking nut is recessed to allow the threaded end of the bar to be hidden when the installation is complete.

Adjustments to the length of the system can still be made after installation without a turnbuckle, by loosening the locking nut and rotating the bar. The extent of this adjustment depends on the size of the bar, but will range from $\pm 9\text{mm}$ for an Ancon 500/8 to $+30\text{mm}$ for an Ancon 500/42.

Stainless steel forks and locking nuts are electro-polished as standard and can also be supplied satin or hand polished.

Each stainless steel fork is supplied with two clear, self-adhesive, PET (polyester) washers to isolate the system from a connecting plate of a dissimilar metal.

Pins

The pins are a two-part construction and once installed are flush with the fork. The installation requires a twin-pin driver. Two driver bits of the appropriate size are supplied with each Ancon system. This type of fixing, known as 'Snake Eyes'*[†], allows a high torque to be achieved without damage to the pin.

The female section of the pin is located through the fork connector and temporarily held in position. A second driver is then used to wind the male section into position creating a secure connection.

Stainless steel pins are supplied with a PTFE coating around the barrel, to isolate the system from a connecting plate of a dissimilar metal.

Compression Systems

Leviat designs and manufactures Compression Systems which comprise standard fork connectors and pins with bespoke high strength tubes, rather than the tie bars shown on page 10. The same selection of materials and surface finishes are available. For more information please contact us.



[†]'Snake Eyes' is the registered trademark of Tamperproof Screw Company Inc.

Tie Bars

Tie bars have a right-hand thread at one end and a left-hand thread at the other. Flats are pressed into the bar close to each end. These allow the bar to be screwed into the fork connectors and adjustments to be made at any time after assembly. Neither couplers nor turnbuckles will be required for applications using a single bar between two forks. The bar is correctly installed when all threads are hidden within the locking nut.

The availability of each size of bar is given on page 14. All bars are cut to a tolerance of $\pm 2\text{mm}$ of the specified length.

Stainless steel bars are bright drawn as standard or hand polished when required.

Couplers

Couplers have right and left hand threads and are used in applications where more than one bar is required between forks. They are supplied with a locking nut for each end of the coupler. Adjustments to the length of the system can still be made after installation, by loosening the locking nut and rotating the bar.

Couplers are machined from bar and can have the provision for a hanger to be fitted to limit the deflection of bars of 16mm diameter or greater. If a hanger is required a lug is welded to the coupler. Stainless steel couplers can be supplied with a polished finish to match the system.

Anchor Discs

Anchor discs allow up to eight bars to be connected together. They can be used at the centre of conventional cross bracing, or where several bars need to be connected at one point. Anchor discs are machined from plate and can be supplied polished or coated to match the surface finish of the tie bars. We can design and manufacture plates in special shapes to replace standard anchor discs and suit the aesthetic requirements of an application.

Cross Couplers

When forming a cross brace, a Cross Coupler offers a streamlined alternative to an anchor disc and minimises the number of fork connectors and locking nuts required. Cross Couplers are available in stainless steel to suit bar sizes from 10 to 24.

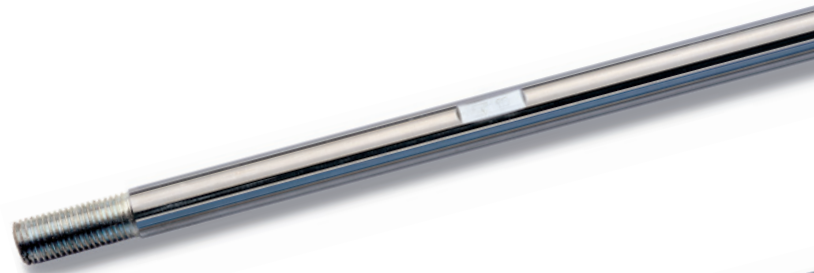

Bright drawn bar

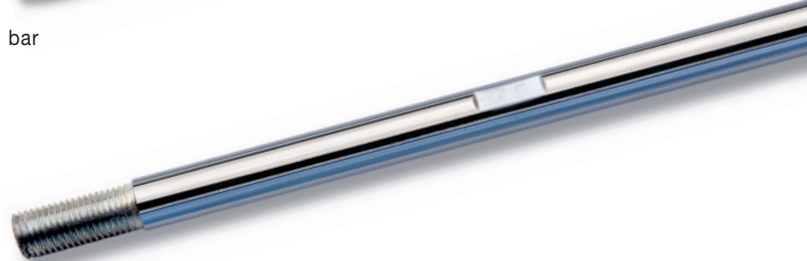

Hand polished bar

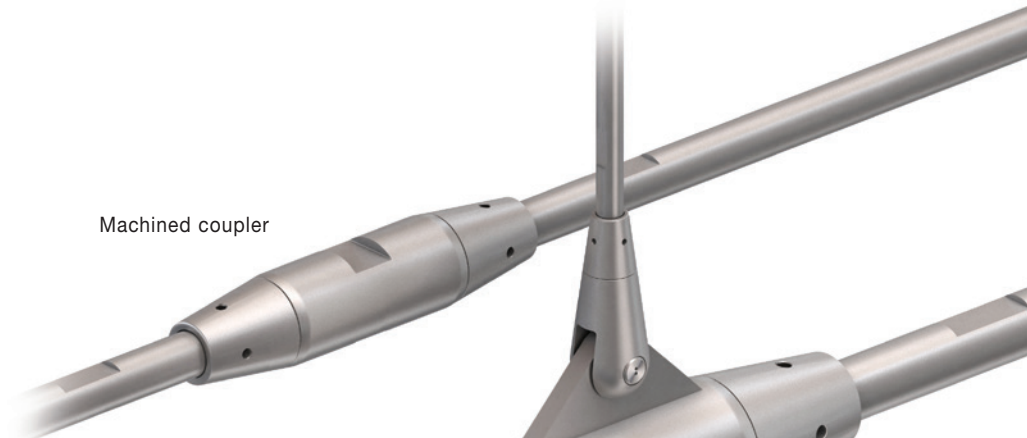

Machined coupler



Coupler with hanger to limit the deflection of long tension bars

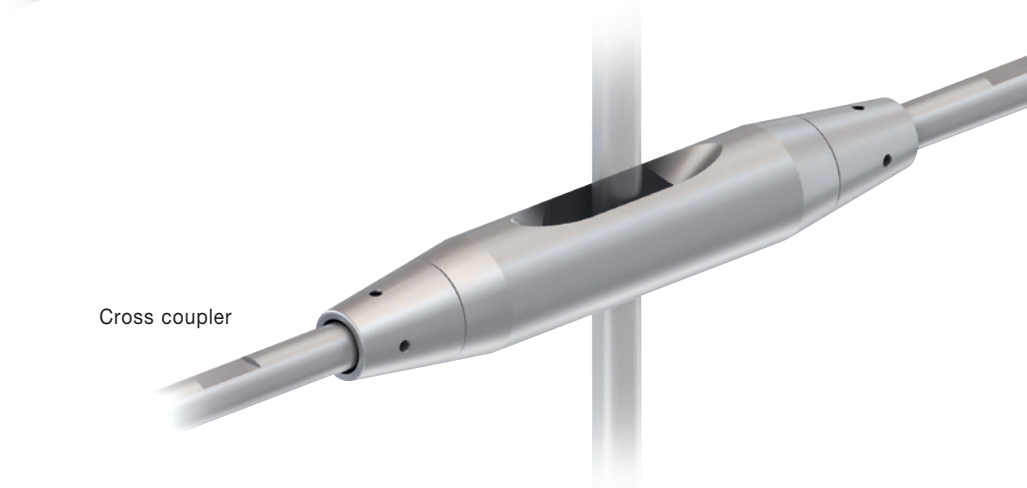

Cross coupler

Tension and Compression Systems

Applications

Leviat has supplied Tension Systems to many structures and buildings. The wide range of components can be used to create a variety of assemblies, from simple tie bars to complex bracing systems involving several bars joined at one point. The following applications demonstrate the variety of uses.



Timber Construction

A combination of timber and steel can use the best properties of each material and achieve a cost-effective and attractive design. Ancon Tension Systems can be connected to the timber compression members, and if high loads are involved, several bars can be used together.

Roof Structures

Trusses and lattice frames which support roofs can benefit from the replacement of tension members with the Ancon system. This will allow generous site adjustments to be made to accommodate inaccuracies within the frame. This would not be possible with a conventionally bolted frame. Tension bars with a high strength, rolled thread are also available.



Canopies

Canopies are frequently supported from above to provide unobstructed access below. Ancon tension bars transfer the load from the front of the canopy back to the main structure or to a mast for free standing canopies.



© Darcy Schack JAM Photographics Ltd

Stainless Steel Systems

Stainless steel is used for applications where a maintenance-free life is important or where a high quality polished finish is required. This can be particularly impressive when used in conjunction with large areas of glazing.

Cross-Bracing

The use of anchor discs or cross couplers forms a cross brace, allowing bars to lie in the same plane. This removes the need to offset bars, with the disc or coupler providing an interesting design feature for the panel.

Glazed Structures

The passage of light is normally a vital consideration in the design of glazed structures.

The small profile of the Ancon Tension System ensures the maximum transmission of light while enhancing the overall appearance of the structure.



Tension and Compression Systems

Performance and Dimensions

The loads indicated below are based on the design method of AS 4100 and include a capacity factor ϕ of 0.9 where the bar governs the design and 0.8 where the fork and pin capacity governs the design. An appropriate load factor will need to be applied to the characteristic loads in accordance with AS/NZS 1170.1

Design Example

Characteristic dead load = 30.0kN $\gamma = 1.2$
 Characteristic imposed load = 22.6kN $\gamma = 1.5$
 Design load = $(30.0 \times 1.2) + (22.6 \times 1.5) = 69.9\text{kN}$
 Use Ancon 500/16
 Design capacity = 84.2kN > 69.9kN

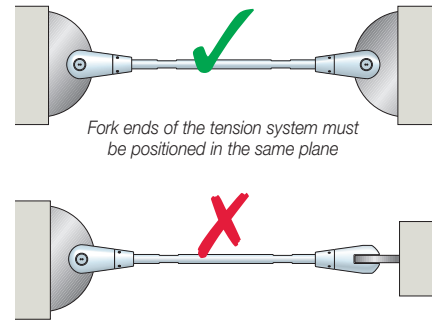

Forks must be correctly aligned, and positioned in the same plane to ensure that bending is not introduced into the tension system.

Ancon Tension Systems are not suitable for dynamic loads.

Ancon 500 Stainless Steel System

Bar Size (mm)	8	10	12	16	20	24	30	36	42
Design Resistances (kN)	17.4	28.8	52.0	84.2	152.4	188.8	300.2	406.1	543.0

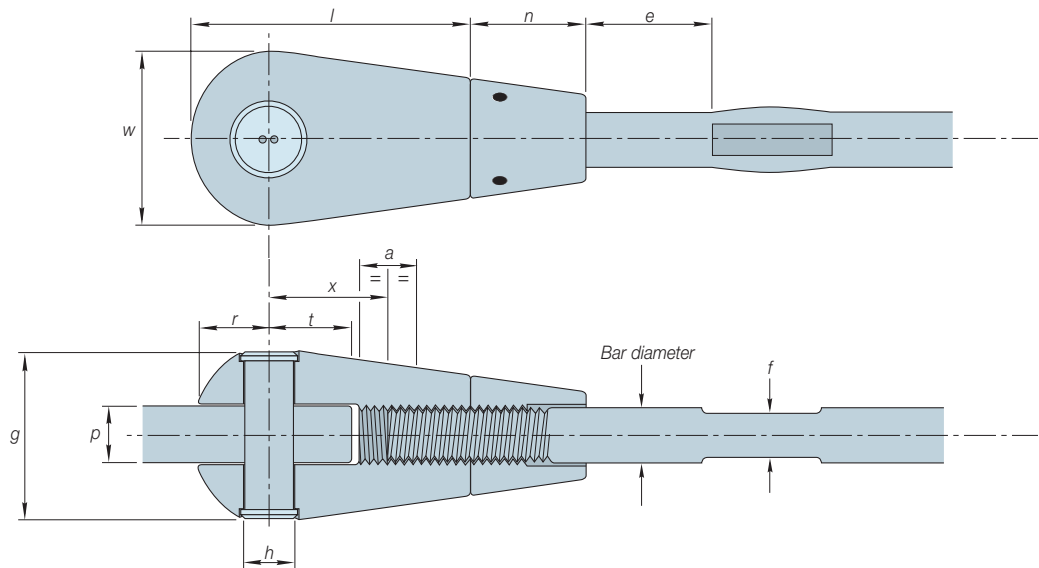

Dimensions of Fork Connectors (mm)

Bar Size		500 System								
		8	10	12	16	20	24	30	36	42
Bar Diameter		8	10	12	16	20	24/25	30	35	42/40
Fork Length	<i>l</i>	40	49	60	78	94	115	140	169	196
Fork Diameter	<i>w</i>	23.5	29	35	48	60	70	89	106	123
Plate Thickness	<i>p</i>	8	10	12	15	20	20	30	30	35
Pin to End	<i>r</i>	10.5	13.5	16	22	28	33	41	50	58
Pin to Plate Edge	<i>t</i>	12	15	18	23	29	36	43	54	63
Hole Diameter for Pin	<i>h</i>	7.5	9.5	11.5	14.5	18.5	21.5	26.5	30.5	35.5
Pin Length	<i>g</i>	23	28.5	34	46	58	68	86	103	118
Adjustment	<i>a</i>	9	10	13	15	16	22	25	28	30
Thickness of Flat	<i>f</i>	6	8	10	14	18	21	27	32	36
Position of Flat	<i>e</i>	17	20	25	38	43	58	69	84	99
Pin to Bar End	<i>x</i>	19	23	27	35.5	42	52	62.5	76	89
Length of Locking Nut	<i>n</i>	18	22	27	33	38	49	60	71	84

Notes: The bar diameter of Ancon 500/24 is 24mm. The bar diameter of Ancon 500/42 is 42mm.

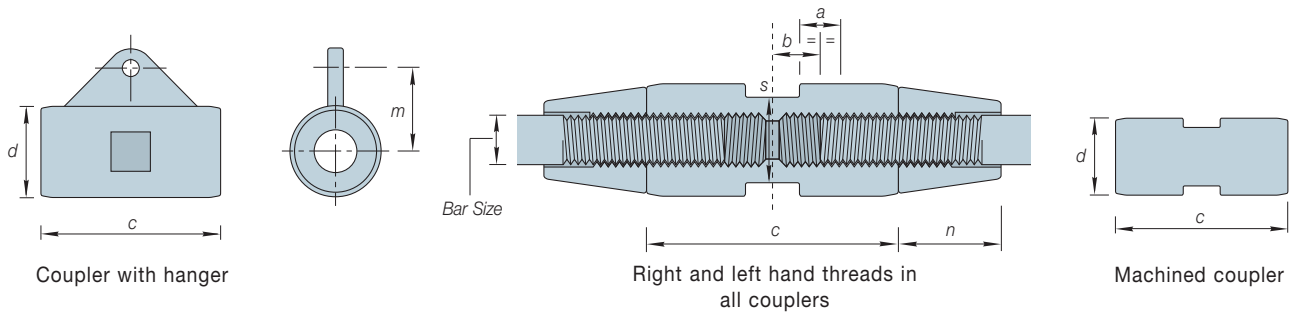

Dimensions of Couplers (mm)

		500 System								
Bar Size		8	10	12	16	20	24	30	36	42
Connector Length	<i>c</i>	38	45	56	83	82	104	125	144.5	166.5
Connector Diameter	<i>d</i>	17	21	25	35	43	52	65	78	90
Adjustment	<i>a</i>	9	10	13	15	16	22	25	28	30
Bar Length Correction	<i>b</i>	8	9.5	11.5	21	17	22	26	29	34
Length of Locking Nut	<i>n</i>	18	22	27	33	38	49	60	71	84
Hanger Bar Diameter		–	–	–	8	8	8	10	10	10
Hole Position	<i>m</i>	–	–	–	33.0	37.0	49.0	59.1	74.5	93.1
Spanner Size (mm A/F)	<i>s</i>	13	17	19	30	36	46	55	65	75



Maximum Bar Lengths

		500 System								
Bar Size (mm)		8	10	12	16	20	24	30	36	42
Bar Length (m)		3	3	6	6	6	6	6	6	6

Note: Material in excess of these lengths can be sourced to meet special project requirements. Contact us for more information.

Minimum Material Specification for Stainless Steel Components

Component	Bar					Fork Connector & Locking Nut		Pin
Bar Size (mm)	8	10	12-20	24-30	36-42	8-12	16-42	8-42
UTS (R_m) N/mm ²	620	650	850	700	650	510	400	520
Yield or 0.2% Proof Stress (R_p) N/mm ²	470	500	780	550	500	355	250	225
Elongation %	40	40	20	20	20	25	25	40
Material Reference	1.4401/4	1.4401/4	1.4462	1.4462	1.4462	1.4462	1.4462	1.4401/4

Tension and Compression Systems

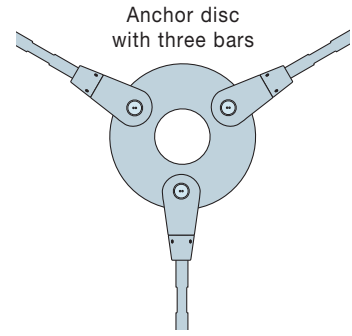
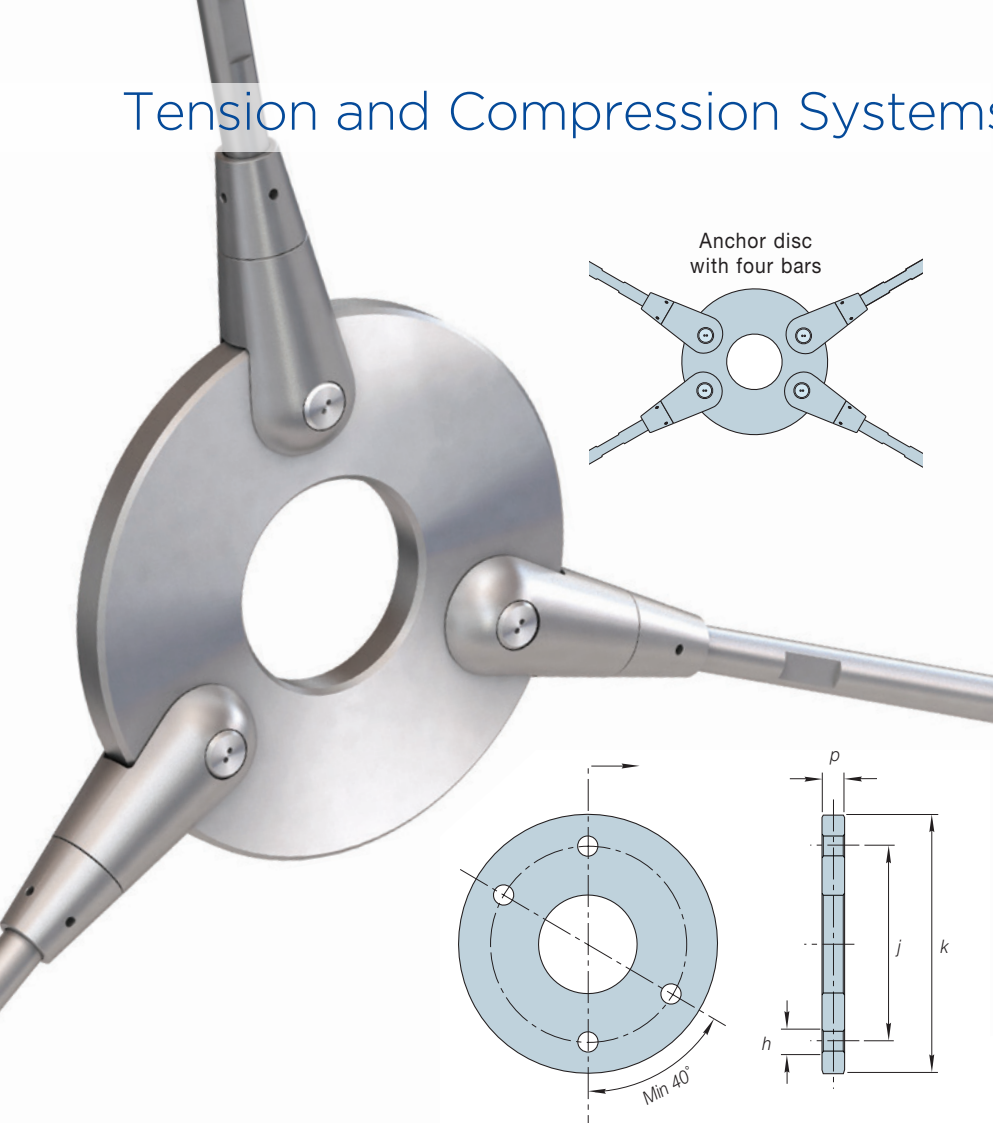

Special Requirements

We can design and manufacture anchor plates in special shapes to replace standard discs and suit the aesthetic requirements of any application.

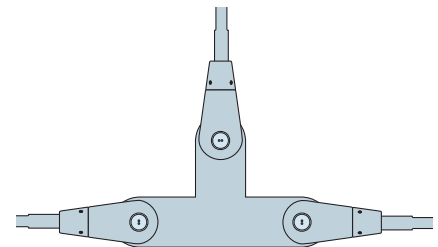

Special anchor plate with three bars

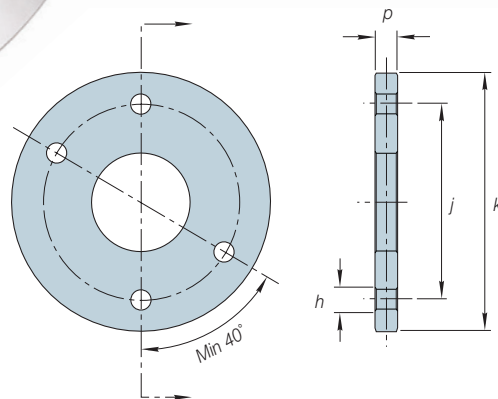

Anchor Discs

Dimensions of Anchor Discs (mm)

Bar Size		500 System								
		8	10	12	16	20	24	30	36	42
Disc Thickness	p	8	10	12	15	20	20	30	30	35
Overall Diameter	k	100	123	148	196	242	282	355	425.5	493.5
Effective Diameter	j	76	93	112	150	184	212	269	318	367
Hole Diameter for Pin	h	7.5	9.5	11.5	14.5	18.5	21.5	26.5	30.5	35.5

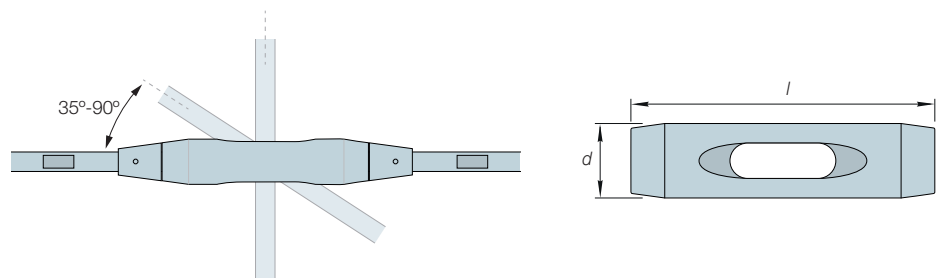
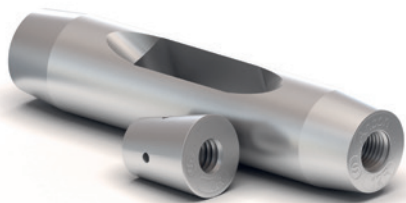

Cross Couplers

Dimensions of Cross Couplers (mm)

Bar Size		500 System				
		10	12	16	20	24
Coupler Length	l	110	126	155	180	210
Coupler Diameter	d	25	28	38	48	58
Diameter of Cross Bar		10	10-12	10-16	10-20	10-24

Connecting Plates

Connecting plates should be designed to suit each application. The critical dimensions are provided in the table and diagrams. In the examples shown here θ is 45° . These plates should be manufactured from 1.4462 stainless steel; users should consider the corrosion properties of the material selected. Isolation material is supplied as standard with the stainless steel tension system to enable its fixing to a connecting plate of a dissimilar metal.

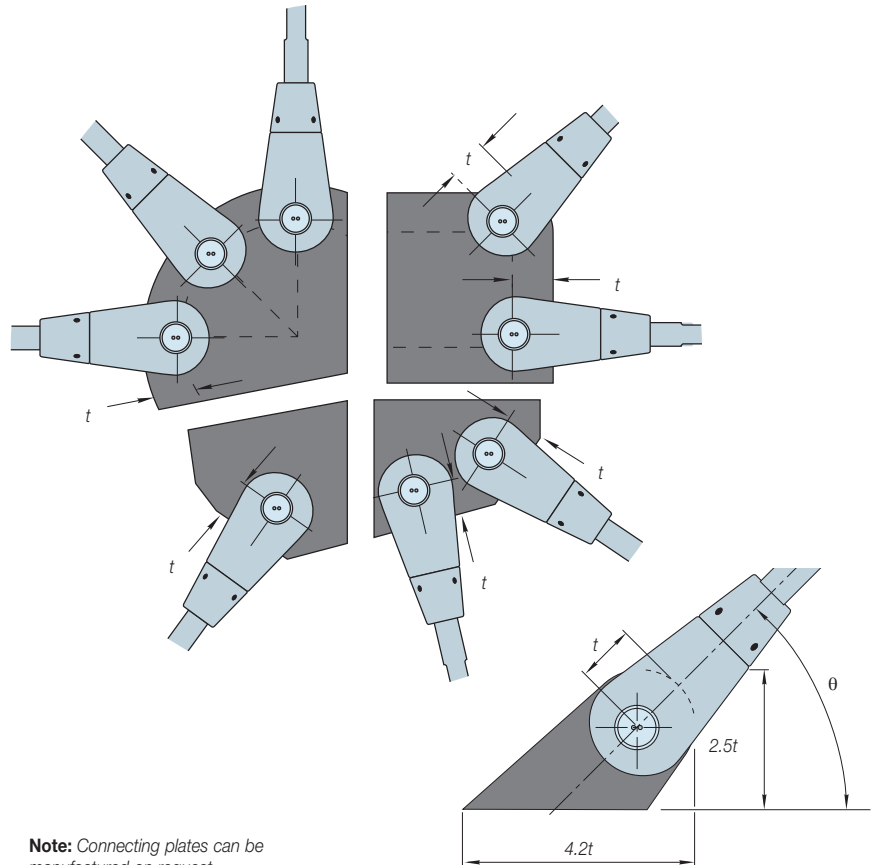
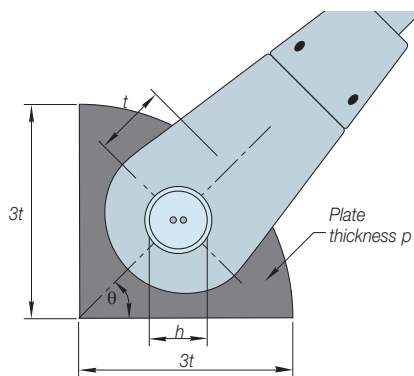

Dimensions of Connecting Plates (mm)

Bar Size	500 System									
	8	10	12	16	20	24	30	36	42	
Plate Thickness	p	8	10	12	15	20	20	30	30	35
Hole Diameter	h	7.5	9.5	11.5	14.5	18.5	21.5	26.5	30.5	35.5
Position of Hole	t	12	15	18	23	29	36	43	54	63

Specifying and Ordering

Ancon Tension Systems are supplied as full systems and are not available as individual components.

System lengths are measured between the centres of the pins in the forks. The maximum bar lengths are shown in the table on page 14 and should be considered when determining the system length.

Stainless steel affords the greatest protection and does not require any further treatment.

The Ancon Tension System can be specified as follows: *System / size / system length / material / finish*.

A fully polished Ancon 500 stainless steel system using 16mm diameter bar, 2750mm between the pins would be specified as:- *Ancon 500/16/2750/SS/6*. The material and finish codes are from the adjacent table.

Please note, Tension & Compression Systems are manufactured in our Europe facilities.

Please contact us for details on lead times.

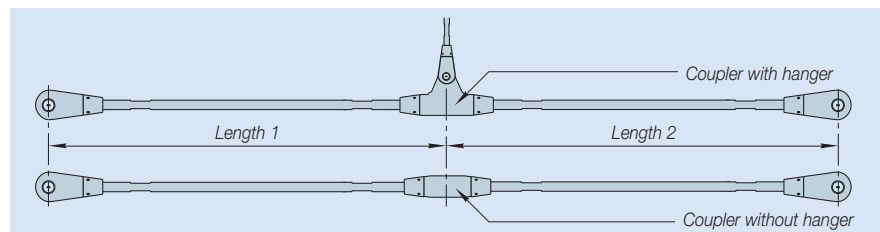
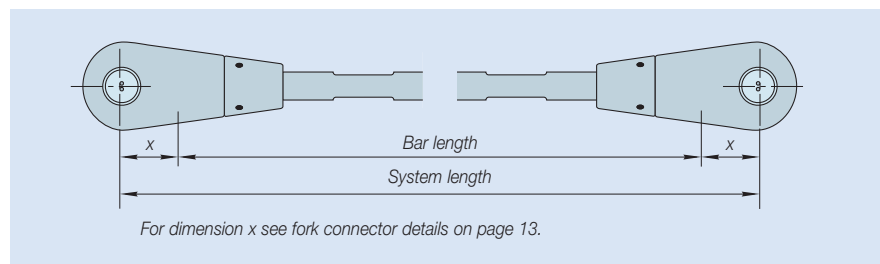

Material and Finish Codes

Code	Material	Bar	Fork & Nut	Surface Finish			Disc
				Coupler	Cross Coupler		
SS/4	Stainless	Bright drawn	Electro-polished	Machined	Electro-polished	Machined	
SS/5	Stainless	Bright drawn	Satin-polished	Satin-polished	Satin-polished	Satin-polished	
SS/6	Stainless	Hand polished	Hand polished	Hand polished	Hand polished	Hand polished	

Tension and Compression Systems

Installation Guidance

It is advisable to assemble tension bars on the ground first, before lifting into position over the connecting plates.

The locking nuts should be fully screwed onto the bar at each end and the bar screwed into the forks, ensuring full thread engagement, using an open-ended spanner of the correct size. The locking nuts must be turned back to the fork and tightened using soft touch pliers for Ancon 500/8 to 500/12 or a hook spanner for Ancon 500/16.

On a level surface as close as possible to the final fixing location, assemble the full system, without pins, to the required pin-to-pin dimension. The full assembly should be lifted over one connecting plate, avoiding excessive sag by using lifting equipment or temporary props as appropriate. Secure the system in place with the pin. Repeat the process at the other connecting point. Final adjustment/tensioning of bars can now take place. Adjustment should be shared between components to ensure adequate bar engagement throughout the system. Tighten the locknuts against fork ends (and couplers if used), ensuring no threads are visible, to complete the installation.

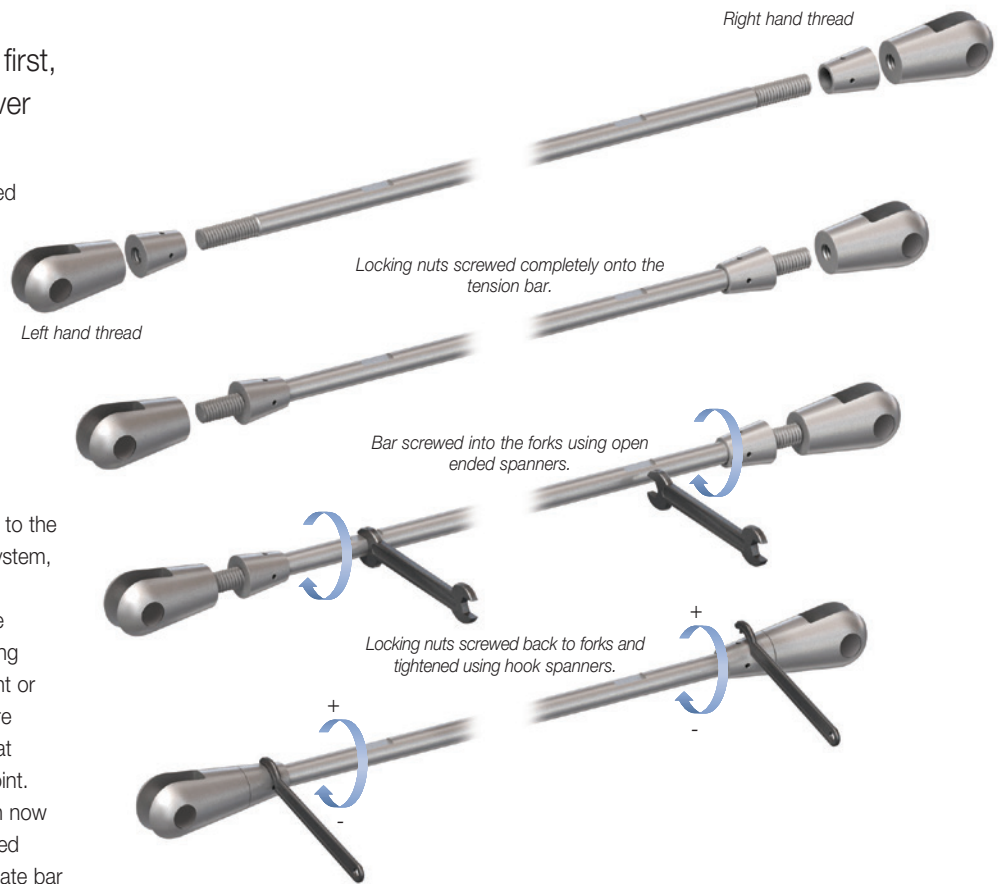

Installing the pin

Two driver bits of the appropriate size are supplied with each Ancon system. The female section of the pin is located through the fork connector and temporarily held in position. A second driver is used to wind the male section into position creating a secure connection.

Isolation material

Each stainless steel fork connector is supplied with two clear, self-adhesive, PET (polyester) washers to isolate the system from a connecting plate of a dissimilar metal. These washers should be applied around the fixing hole, either side of the plate, prior to the installation of the fork connector.

Incorrect installation



Correct installation with no thread visible



Fork Connector Alignment

Forks must be correctly aligned, and positioned in the same plane to ensure that bending is not introduced into the tension system.

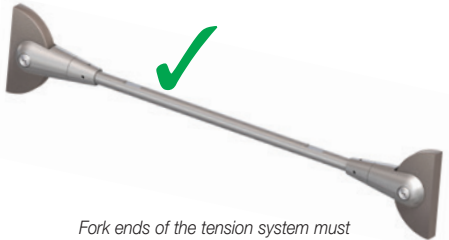

The maximum misalignment of an Ancon System is 0.5° as illustrated below.

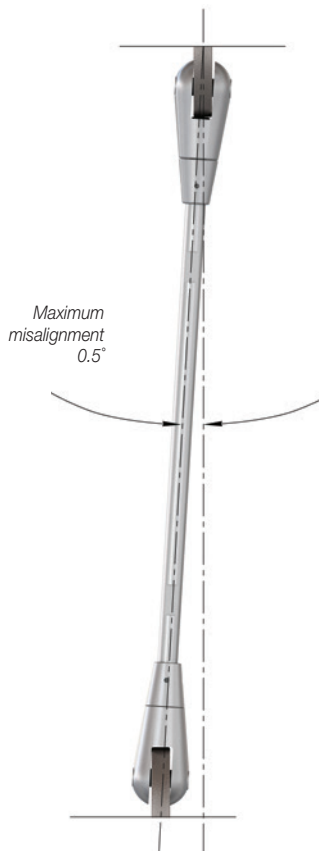

For further information or advice on specific applications please contact our Technical Services Team.

Other Ancon Products

Wall Ties and Restraint Fixings

In addition to standard cavity and veneer wall ties, Leviat manufactures ties in a variety of lengths and types for restraining brickwork, blockwork and stonework. These ties can be fixed to concrete and structural steelwork, as well as any type of masonry.

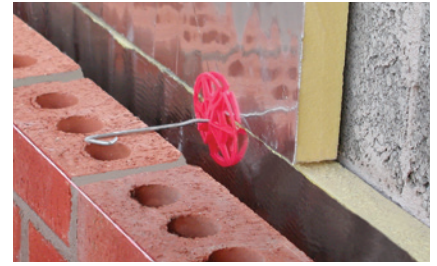

Masonry Support Systems

Masonry cladding on concrete or steel frames is normally supported from stainless steel support systems. Ancon MDC Systems create a continuous angle to support the outer leaf of masonry. Ancon Individual Brackets support masonry features such as curves and arches. A full design service is available to specifiers and users of Ancon systems.

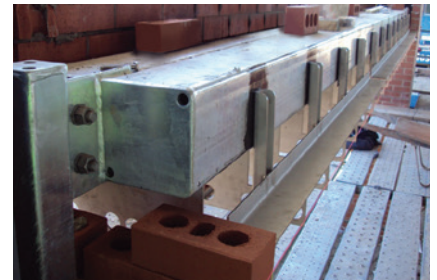

Shear Load Connectors

Ancon DSD and ESD Shear Load Connectors are used to transfer shear across expansion and contraction joints in concrete. They are more effective at transferring load and allowing movement to take place than standard dowels, and can be used to eliminate double columns at structural movement joints in buildings. A 'Lockable' dowel is also available for temporary movement joints in post-tensioned concrete frames.



Special Fabrications

Leviat is an ASSDA accredited specialist fabricator and has a wealth of experience in working with a variety of material grades. High integrity steel components are supplied to a wide range of industries including Civil Engineering, Building, Infrastructure, Water Treatment, Nuclear and Mining.



© Thiess, Energy Australia

Precast Concrete Accessories

Leviat offers an unrivalled service to the precast concrete industry. Our technical and sales support services, extensive product range and nationwide operations, enable us to provide a customer focused service that is second to none. Our product portfolio of lifting, fixing and anchoring technologies includes European-engineered systems and market leading brands.



Worldwide contacts for Leviat:

Australia

Leviat
98 Kurrajong Avenue,
Mount Druitt Sydney, NSW 2770
Tel: +61 - 2 8808 3100
Email: info.au@leviat.com

Austria

Leviat
Leonard-Bernstein-Str. 10
Saturn Tower, 1220 Wien
Tel: +43 - 1 - 259 6770
Email: info.at@leviat.com

Belgium

Leviat
Industrielaan 2
1740 Ternat
Tel: +32 - 2 - 582 29 45
Email: info.be@leviat.com

China

Leviat
Room 601 Tower D, Vantone Centre
No. A6 Chao Yang Men Wai Street
Chaoyang District
Beijing · P.R. China 100020
Tel: +86 - 10 5907 3200
Email: info.cn@leviat.com

Czech Republic

Leviat
Business Center Šafránková
Šafránková 1238/1
155 00 Praha 5
Tel: +420 - 311 - 690 060
Email: info.cz@leviat.com

Finland

Leviat
Vädursgatan 5
412 50 Göteborg / Sweden
Tel: +358 (0)10 6338781
Email: info.fi@leviat.com

France

Leviat
6, Rue de Cabanis
FR 31240 L'Union
Toulouse
Tel: +33 - 5 - 34 25 54 82
Email: info.fr@leviat.com

Germany

Leviat
Liebigstrasse 14
40764 Langenfeld
Tel: +49 - 2173 - 970 - 0
Email: info.de@leviat.com

India

Leviat
309, 3rd Floor, Orion Business Park
Ghodbunder Road, Kapurbawdi,
Thane West, Thane,
Maharashtra 400607
Tel: +91 - 22 2589 2032
Email: info.in@leviat.com

Italy

Leviat
Via F.lli Bronzetti 28
24124 Bergamo
Tel: +39 - 035 - 0760711
Email: info.it@leviat.com

Malaysia

Leviat
28 Jalan Anggerik Mokara 31/59
Kota Kemuning, 40460 Shah Alam
Selangor
Tel: +603 - 5122 4182
Email: info.my@leviat.com

Netherlands

Leviat
Oostermaat 3
7623 CS Borne
Tel: +31 - 74 - 267 14 49
Email: info.nl@leviat.com

New Zealand

Leviat
2/19 Nuttall Drive, Hillsborough,
Christchurch 8022
Tel: +64 - 3 376 5205
Email: info.nz@leviat.com

Norway

Leviat
Vestre Svanholmen 5
4313 Sandnes
Tel: +47 - 51 82 34 00
Email: info.no@leviat.com

Philippines

Leviat
2933 Regus, Joy Nostalg,
ADB Avenue
Ortigas Center
Pasig City
Tel: +63 - 2 7957 6381
Email: info.ph@leviat.com

Poland

Leviat
Ul. Obornicka 287
60-691 Poznań
Tel: +48 - 61 - 622 14 14
Email: info.pl@leviat.com

Singapore

Leviat
14 Benoi Crescent
Singapore 629977
Tel: +65 - 6266 6802
Email: info.sg@leviat.com

Spain

Leviat
Polígono Industrial Santa Ana
c/ Ignacio Zuloaga, 20
28522 Rivas-Vaciamadrid
Tel: +34 - 91 632 18 40
Email: info.es@leviat.com

Sweden

Leviat
Vädursgatan 5
412 50 Göteborg
Tel: +46 - 31 - 98 58 00
Email: info.se@leviat.com

Switzerland

Leviat
Grenzstrasse 24
3250 Lyss
Tel: +41 - 31 750 3030
Email: info.ch@leviat.com

United Arab Emirates

Leviat
RA08 TB02, PO Box 17225
JAFZA, Jebel Ali, Dubai
Tel: +971 (0)4 883 4346
Email: info.ae@leviat.com

United Kingdom

Leviat
President Way, President Park,
Sheffield, S4 7UR
Tel: +44 - 114 275 5224
Email: info.uk@leviat.com

United States of America

Leviat
6467 S Falkenburg Rd.
Riverview, FL 33578
Tel: (800) 423-9140
Email: info.us@leviat.us

For countries not listed

Email: info@leviat.com

Leviat.com

Notes regarding this catalogue

© Protected by copyright. The construction applications and details provided in this publication are indicative only. In every case, project working details should be entrusted to appropriately qualified and experienced persons. Whilst every care has been exercised in the preparation of this publication to ensure that any advice, recommendations or information is accurate, no liability or responsibility of any kind is accepted by Leviat for inaccuracies or printing errors. Technical and design changes are reserved. With a policy of continuous product development, Leviat reserves the right to modify product design and specification at any time.

For more information on the following products, please contact:

**Masonry, Structural and
Precast Concrete products:**

+64 (0) 3 376 5205
info.ancon.nz@leviat.com
Ancon.co.nz

**Remedial Masonry
products:**

+64 (0) 3 376 5205
info.helifix.nz@leviat.com
Helifix.co.nz

General Enquiries

+64 (0) 3 376 5205
Leviat.com

Sales Offices and Production

North Island:

246D James Fletcher Drive
Otahuhu
Auckland 2024
New Zealand

South Island:

2/19 Nuttall Drive
Hillsborough
Christchurch 8022
New Zealand

Leviat.com

Leviat[®]
A CRH COMPANY

Imagine. Model. Make.

Leviat.com