

## USE OF TOOTHED ANCHOR CHANNELS IN SEISMIC REGIONS

ANDREAS BOOMKAMP

Ancon Building Products

Designing anchorage points to concrete is a common challenge for structural engineers, specifically for applications that must resist seismic loading. It is important that the designer fully understands the mechanism of the chosen anchoring product and the influence that the mechanism has on the system performance for the specific conditions of the application.

Anchor systems can be divided in cast-in place systems and post-installed systems. Figure 1 gives an overview over the different types of systems that are currently available.

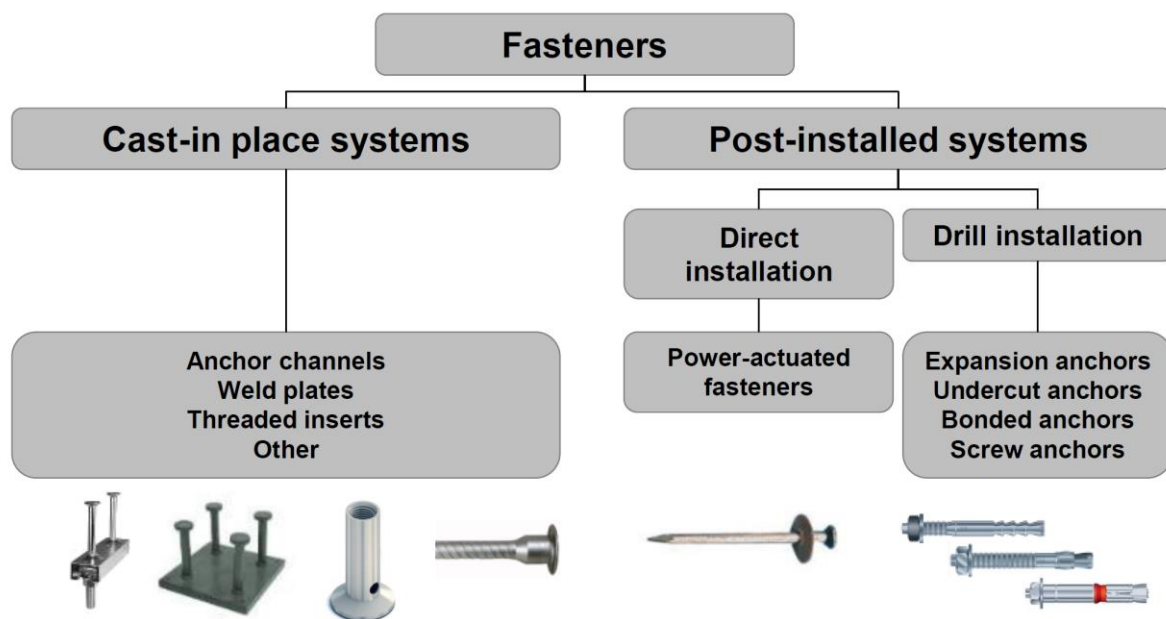

Figure 1 – Fastening methods in concrete

Cast-in place systems like threaded inserts, also called ferrules, are limited in their application as they do not allow for building tolerances. Weld plates allow for limited tolerances but do not meet the demand of modern construction sites as they require on site welding causing safety issues and slow down the overall building process.

Post installed systems can accommodate to building tolerances but their installation is slow in comparison to threaded cast-in place solutions.

While cast-in place systems normally depend on headed anchors to transfer the load in the concrete, most post-installed anchor systems rely on friction or adhesive bond.

NZS 3101<sup>1</sup> – Chapter 17.5.5 requires post installed anchors used in cracked concrete under seismic conditions to be explicitly qualified. If an anchor is positioned in a concrete tension zone the concrete must be assumed as cracked. If cracks open near or even through the anchor location they will negatively affect the ability to transfer stresses from the anchor into the surrounding concrete.

Besides the negative impact of cracking on the capacity of post installed anchors, chemical anchor systems will also show a big impact on the bearing capacity when installed improperly. Studies in different parts of the world have shown that a proper cleaning of the bore hole like described in the manufacturer’s installation instruction is often not done leading to a significant decrease in capacity of epoxy anchors. In catastrophic failures of post installed anchors like the “Big dig tunnel collapse” with one fatality in Boston, U.S. in 2006 or the Sasogo tunnel accident in Japan with 9 fatalities in 2012, the identified issues always included improper anchor installation as well as insufficient inspection <sup>2,3</sup>.

Anchor Channels, either hot-rolled or cold-formed C-shaped channel profiles with at least two I-shaped anchors welded to the back, are a safe and efficient method of anchoring tension and shear loads into both cracked and un-cracked concrete. The Anchor Channels are installed before the concrete is poured, normally by nailing them to the inside of the formwork. The installation is easy and leaves little room for installation errors that could cause a reduction of the system capacity. The internal space of the channel profile is filled with a removable form filler to avoid concrete intrusion. Loads are introduced by channel bolts, also called T-bolts, which are inserted into the channel slot and transfer the loads safely into the channel through the channel lips. The channel bolts provide the adjustability required to compensate for construction tolerances.

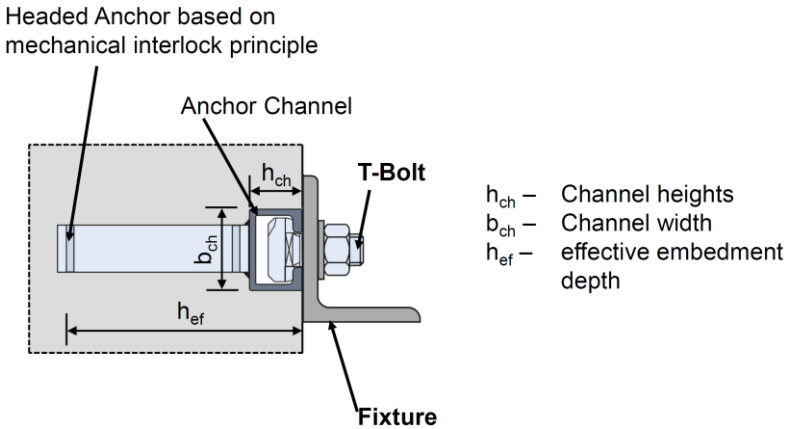

Figure 2 – Anchor Channel fixture

There is a wide range of applications for anchor channels in structures. Figure 3 shows some common applications.

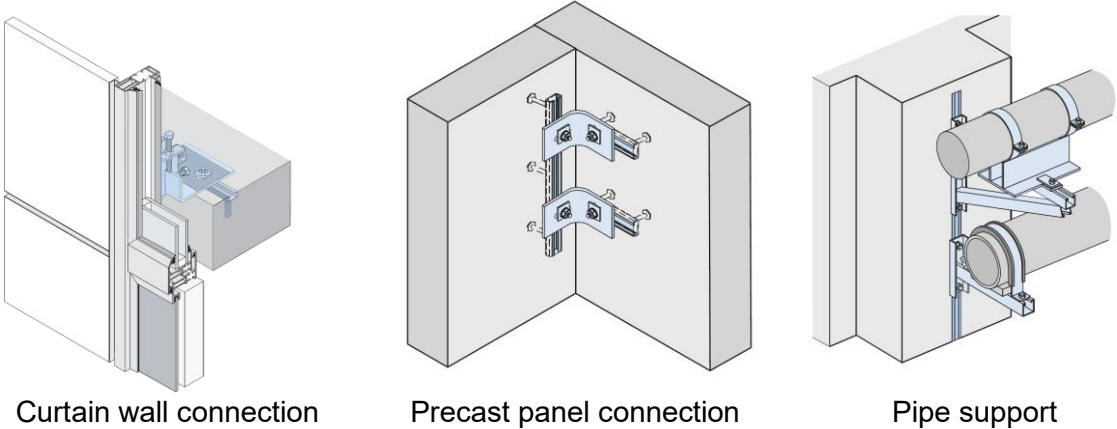

Figure 3 – Common applications of anchor channels

Anchor Channels are regulated in Europe respective qualification with the European Assessment Document (EAD) 330008-02-0601<sup>4</sup> and relating to design with the standard EN 1992-4, in the United States of America with AC232 - Acceptance Criteria for anchor channels in Concrete<sup>5</sup> by the Evaluation Service of the International Code Council (ICC-ES), and in Australia by SA TS 101 - Design of post-installed and cast-in fastenings for use in concrete<sup>6</sup>. All three documents promote the same design method for tension loads as well as shear loads perpendicular to the longitudinal axes of the anchor channel. Since February 2016, AC232 also covers loads in the longitudinal axis of the anchor channel and includes the design for seismic conditions allowing their use in all seismic design categories (A – F) provided the channels are capable of providing resistance in all three axes. A common approach to achieve a load capacity in the longitudinal direction is to use so called toothed anchor channels.

Toothed Anchor Channels contain serrations along the inside of the channel lips and are used with channel bolts with a matching serration. The channel and bolt serrations create an interlock between the two surfaces which provides a positive connection capable of resisting shear loads in the longitudinal direction of the channel axis. Toothed Anchor Channels have been used in multiple projects worldwide including the anchoring of the curtain wall façade of the Broad Museum in Los Angeles which required particular attention to seismic design<sup>7</sup>. Plain anchor channels with plain T-bolts can take over longitudinal loads based on the friction between the channel and the T-bolt, but the capacity relies on the torque of the T-bolt. International standards and regulations do not allow friction based connections and thus plain anchor channels in combination with plain T-bolts cannot be used in applications that require longitudinal loading.

Figure 4 shows anchor channels with plain and serrated lips and the load directions the systems can withstand.

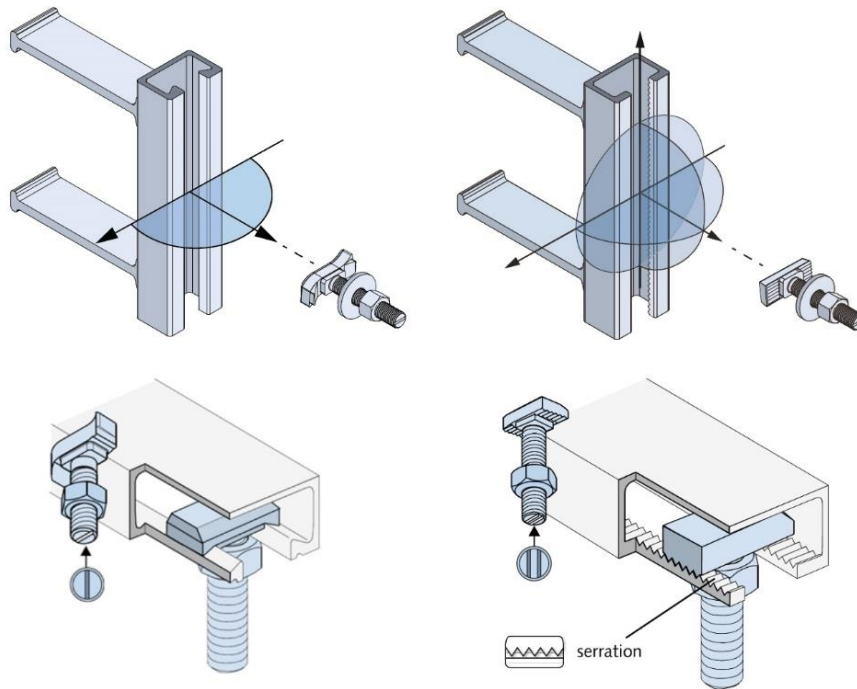

Figure 4 – Anchor channels with plain and toothed lips and T-bolts

AC 232 provides definitions for loads and dimensions regarding anchor channels:

- $s$  = Anchor Spacing
- $N_{ua}$  = Tension Load on T-bolt
- $V_{ua,y}$  = perpendicular shear load on T-bolt
- $V_{ua,x}$  = Longitudinal shear load on T-bolt
- $c_{a1}$  = Edge spacing
- $s_{chb}$  = T-bolt spacing

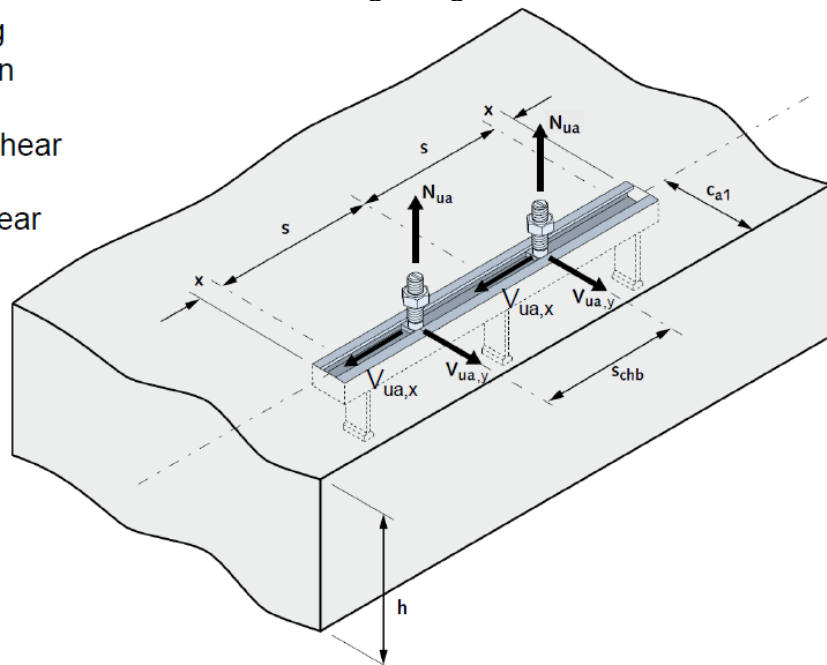

Figure 5 – Definitions according to AC 232

The tension loads  $N_{ua}$  and shear loads  $V_{ua}$  are introduced in the Anchor channel through the T-bolts and distributed into the anchors. The nomenclature for the anchor loads is  $N_{ua,i}^a$  for a tension load in the anchor  $i$  and  $V_{ua,i}^a$  for the shear load in the anchor  $i$ .

The design concept presented in AC 232 is based on the design for anchors in concrete as introduced in ACI 318, chapter 17. AC 232 includes additional sections to address the failure modes unique to anchor channels.

AC 232 introduces a method to calculate, how the loads introduced through the T-bolts are distributed in the anchors based on the stiffness of the channel profile. Depending on the failure mode under investigation the design will use the load on the T-bolt or the load on the anchor in the design process. AC 232 contains provisions for the design of anchor channels for the failure modes shown in the following tables.

Table 1 - Failure modes, loads, and capacities as defined in AC 232 – tension

Failure modes tension		
Steel failure of channel bolt	$\phi \cdot N_{ss} \geq N_{ua}$	
Flexure failure of channel lips	$\phi \cdot N_{sl} \geq N_{ua}$	
Flexure failure of channel	$\phi \cdot M_{s,flex} \geq M_{u,flex}$	
Failure of connection between anchor and channel	$\phi \cdot N_{sc} \geq N_{ua}^a$	
Steel failure of anchor	$\phi \cdot N_{sa} \geq N_{ua}^a$	
Pullout failure	$\phi \cdot N_p \geq N_{ua}^a$	
Concrete cone failure	$\phi \cdot N_{cb} \geq N_{ua}^a$	

Table 2 - Failure modes, loads, and capacities as defined in AC 232 – perpendicular shear

Failure modes perpendicular shear		
Steel failure of channel bolt	$\phi \cdot V_{ss} \geq V_{ua,y}$	
Flexure failure of channel lips	$\phi \cdot V_{sl,y} \geq V_{ua,y}$	
Failure of connection between anchor and channel	$\phi \cdot V_{sc,y} \geq V_{ua,y}^a$	
Concrete Edge Failure	$\phi \cdot V_{cb,y} \geq V_{ua,y}^a$	
Pryout failure	$\phi \cdot V_{cp,y} \geq V_{ua,y}^a$	

Table 3 - Failure modes, loads, and capacities as defined in AC 232 – longitudinal shear

Failure modes longitudinal shear		
Steel failure of channel bolt	$\phi \cdot V_{ss} \geq V_{ua,x}$	
Failure of connection channel lips and channel bolt	$\phi \cdot V_{sl,x} \geq V_{ua,x}$	
Steel failure of anchor	$\phi \cdot V_{sa,x} \geq V_{ua,x}^a$	
Concrete Edge Failure	$\phi \cdot V_{cb,x} \geq V_{ua,x}^a$	
Pryout failure	$\phi \cdot V_{cp,x} \geq V_{ua,x}^a$	

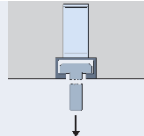
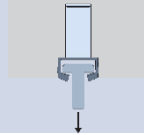
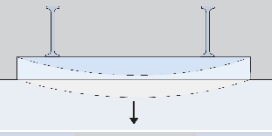
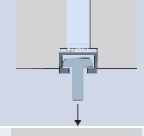
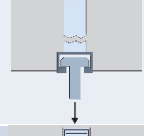
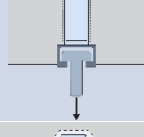
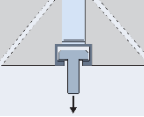
The design introduced in AC 232 relies on the concrete cone capacity design (CCD) method for the capacity of the concrete in tension. The CCD method is internationally accepted as a method to calculate the capacity of anchors in concrete for both, cast-in place systems and post installed systems. The CCD as described by Eligehausen, Mallée and Silva<sup>8</sup> is confirmed through a wide database of tests and referenced in chapter 17 of NZS 3101<sup>1</sup>.

For the product specific failure modes related to anchor channels, AC 232 describes 14 test series to determine the capacities:

Table 4 – Test series as described in AC 232

Test series	Capacity	Test type
1, 2, 3	$N_{ss}, (N_{sa}), N_{sl}, N_{sc}$	Steel failure tension
4	$M_{s,flex}$	
5	Torque test	
6	$N_{ch,sp}$	Concrete failure tension
8	$V_{sl}, V_{sc,y}, V_{sa,y}$	Steel failure shear load
10	$V_{cb,y}$	Concrete failure shear load
12	Seismic tension	Seismic testing
13	Seismic shear y	
14	Seismic shear x	
15	$V_{sl,x}$	Steel failure longitudinal shear
16	$V_{sl,x}$	
17	$V_{sl,x}$	

The following images were taken during the independent testing in the approval process:

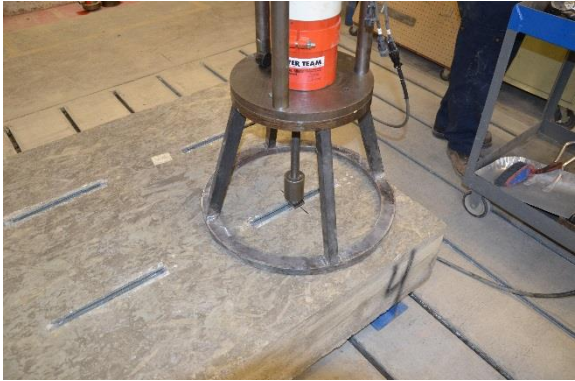

Figure 6 – Test series 4 – Channel bending



Figure 7 – Test series 10 – Concrete failure shear load



Figure 8 – Test series 12 – Seismic Tension



Figure 9 – Test series 13 – Seismic Shear



Figure 10 – Test series 15 – Steel failure longitudinal shear



Figure 11 – Damaged Teeth inside the channel lip after longitudinal shear test

Provisions in ACI 318-14 - Building Code Requirements for Structural Concrete<sup>9</sup> as well as in NZS 3101<sup>1</sup> require ductile, flexural behaviour modes of structural members instead of brittle modes of failure. The failure modes of anchor channels that are related to steel are considered ductile. For Anchor Channels that are used with large distances to the next edge the capacity of the surrounding concrete will normally exceed the steel capacity of the anchor channel resulting in a ductile failure mode of the system. For conditions where the factored tensile and shear loads exceed the concrete breakout strength, especially when Anchor Channels are placed close to the edge of a concrete member, it is permitted within AC 232 that the nominal strength can be that of the anchor reinforcement properly placed as shown in the images below.

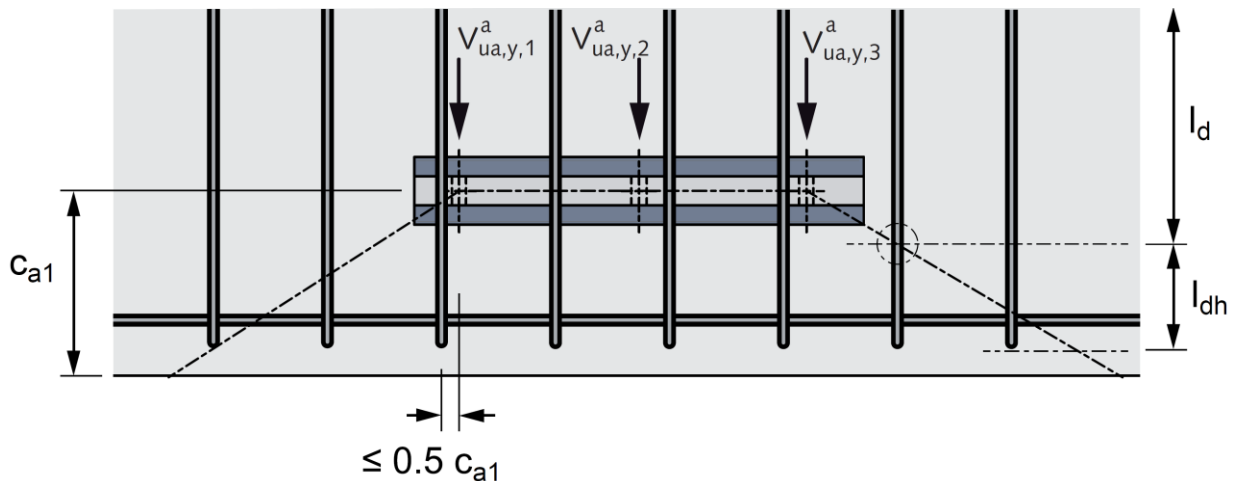

Figure 12 – Anchor reinforcement to withstand shear loads



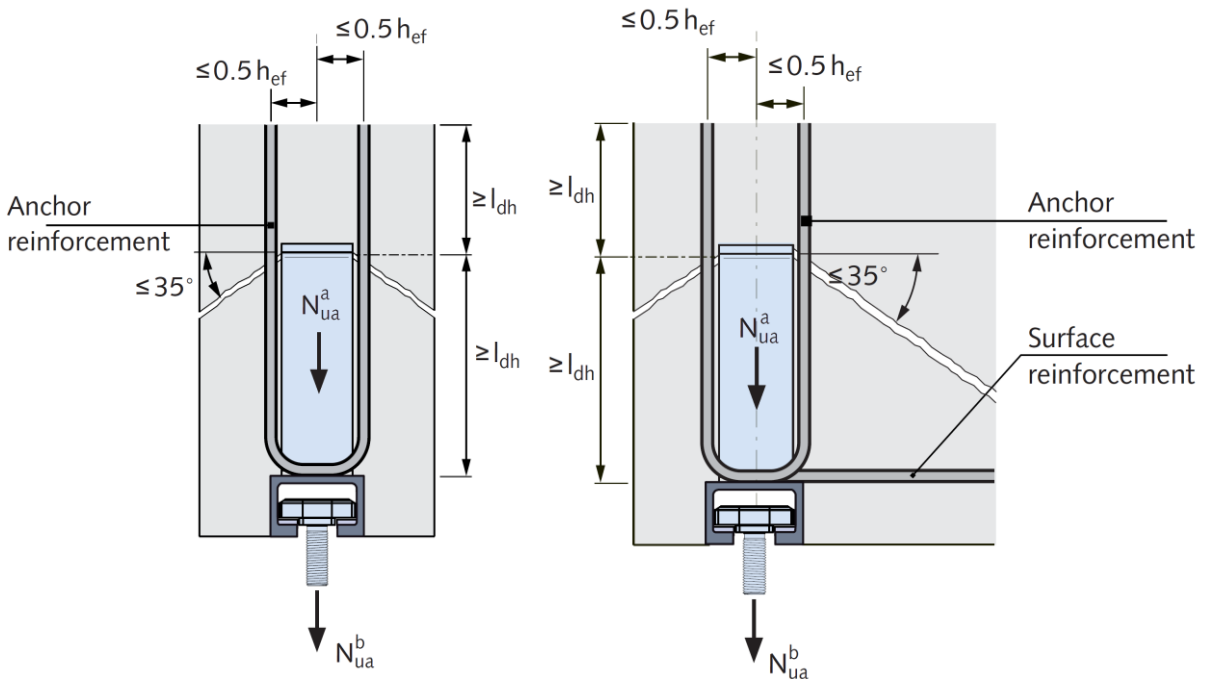

Figure 13 - Anchor reinforcement to withstand tension loads

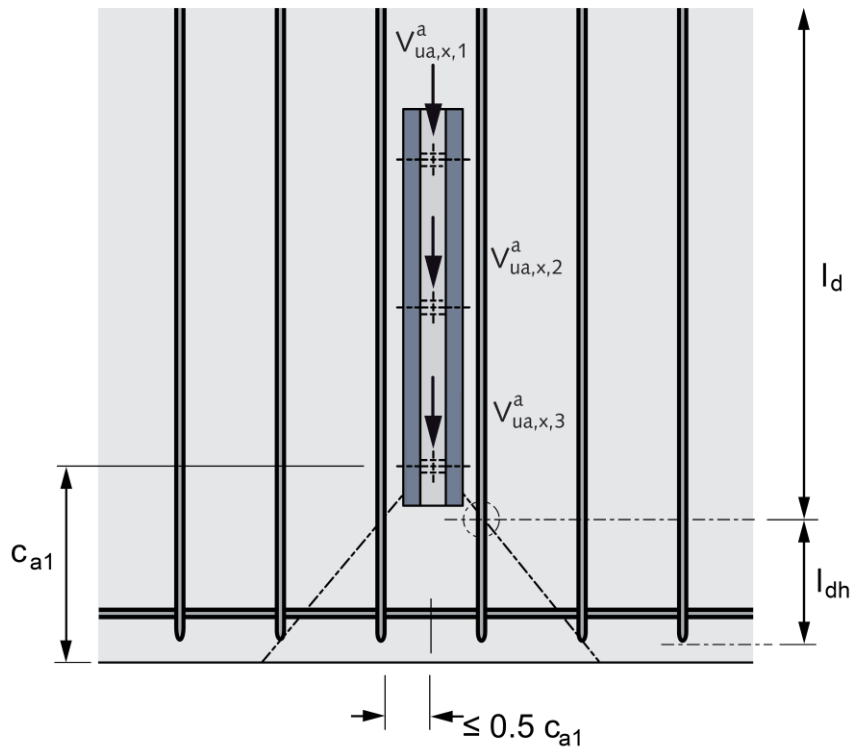

Figure 14 - Anchor reinforcement to withstand longitudinal shear

Anchor reinforcement should consist of stirrups, ties or hairpins comprised of formed reinforcing bars with a maximum diameter of 16mm. Reinforcement bars shall be placed as close as possible to the anchors of the Anchor Channel. It is recommended that the reinforcement bar is fully developed in accordance with NZS 3101 on both sides of the breakout surface of an anchor. The use of reinforcement to increase the capacity of cast-in anchors is consistent with the requirements described in C17.5.6.1 in the commentary section of NZS 3101.

The author thinks that the design approach as described in AC 232 allows for a design of toothed anchor channels that complies with the requirements of NZS 3101. When designed in accordance with the provisions given in this article, toothed anchor channels are a safe and reliable way to connect to concrete. The use of the slotted connection will allow the adjustability required to overcome building tolerances and the absence of welding in the connection speeds up the construction process and increases safety.

## **REFERENCES**

- 1 - NZS 3101:2006 – Concrete Structures Standard
- 2 - National Transportation Safety Board – Accident Report HAR 07-02
- 3 - Ministry of Land, Infrastructure, Transport and Tourism – MLIT Pres Release July 2013
- 4 - DIBt, European Assessment Document (EAD) 330008-02-0601
- 5 - ICC-ES, AC 232 Acceptance Criteria for Anchor Channels in Concrete
- 6 - Standards Australia, SA TS 101 - Design of post-installed and cast-in fastenings for use in concrete
- 7 - HALFEN USA Inc., The Broad Art Museum, Los Angeles, CA
- 8 - Eligehausen, Mallée, Silva - Anchorage in Concrete Construction, 2006
- 9 - ACI 318-14 - Building Code Requirements for Structural Concrete, 2014