

ICC-ES Appraisal Report

ESA-2023

Reissued December 2023

Subject to renewal December 2024

ICC-ES Evaluation Reports are not to be construed as representing aesthetics or any other attributes not specifically addressed, nor are they to be construed as an endorsement of the subject of the report or a recommendation for its use. There is no warranty by ICC Evaluation Service, LLC, express or implied, as to any finding or other matter in this report, or as to any product covered by the report.

Copyright © 2023 ICC Evaluation Service, LLC. All rights reserved.

<p>DIVISION: 03 00 00 — CONCRETE</p> <p>Section: 03 15 19 — Cast-in Concrete Anchors</p> <p>Section: 03 16 00 — Concrete Anchors</p>	<p>REPORT HOLDER: LEVIAT GmbH</p>  <p>A CRH COMPANY</p>	<p>EVALUATION SUBJECT: HALFEN HZA ANCHOR CHANNELS AND HZS CHANNEL BOLTS</p>	
---	---	--	---

1.0 EVALUATION SCOPE

Compliance with the following code:

- [New Zealand Building Code](#): Building Regulations 1992 Version as at 15 November 2021. (2021 NZBC)

Compliance with the following performance requirements:

- **Clause B1 Structure**: NZBC Clauses B1.3.1, B1.3.2, B1.3.3 and B1.3.4.

Design of the HALFEN HZA anchor channels and HALFEN HZS channel bolts described in this report must take into account physical conditions likely to affect the stability of the structure, including imposed gravity loads arising from use, earthquake and wind (See NZBC Clause B1.3.3 (b), (f) and (h)). See Section 4.1 and 4.2 of this report.

- **Clause B2 Durability**: NZBC Clause B2.3.1(a).

The HALFEN HZA anchor channels and HALFEN HZS channel bolts, when maintained in accordance with this report, satisfies the performance of this code for the life of the building, being not less than 50 years. See Section 4.3 of this report.

- **Clause F2 Hazardous Building Materials**: NZBC Clause F2.3.1.

The HALFEN HZA anchor channels and HALFEN HZS channel bolts meet the performance requirements under Clause F2.3.1.

The HALFEN HZA anchor channels and HALFEN HZS channel bolts are not subject to a warning or ban under the New Zealand Building Act 2004, Version as at 7 September 2022.

2.0 USES

HALFEN HZA anchor channels and HALFEN HZS channel bolts are used as anchorage in concrete to resist static

(i.e. permanent and imposed actions), wind, and seismic tension loads (N_{ua}), shear loads perpendicular to the longitudinal channel axis ($V_{ua,y}$), and shear loads longitudinal to the channel axis ($V_{ua,x}$), or any combination of these loads (as illustrated in [Figure 1](#)) applied at any location between the outermost anchors of the anchor channel.

The use is limited to cracked or uncracked normal-weight concrete having a specified compressive strength, f'_c , of 2,900 psi to 10,000 psi (20.0 MPa to 69.0 MPa) The anchor channels are an alternative to anchors described in Section 17.2 of the NZS 3101: Part 1:2006, as permitted by Section 3.6 of the New Zealand Building Code Handbook (2014).

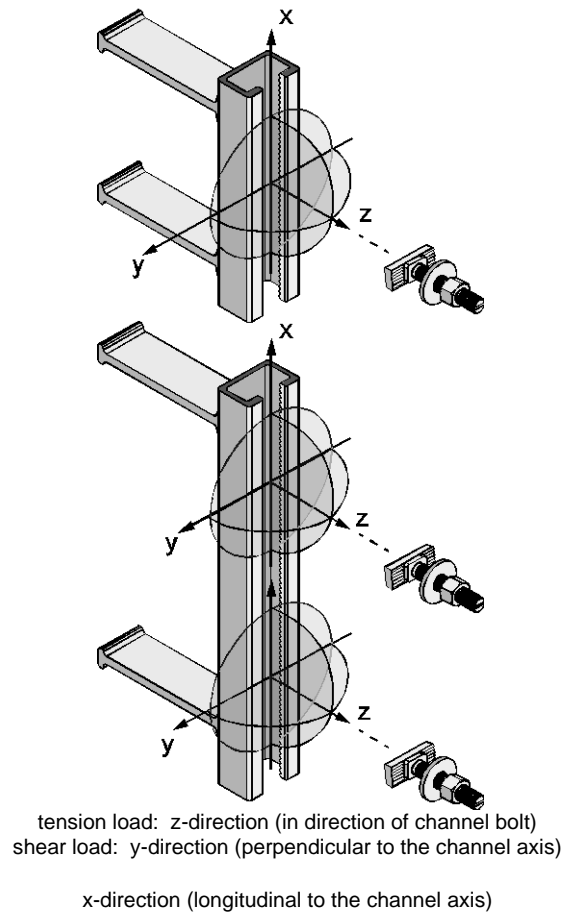

FIGURE 1—LOAD DIRECTIONS

3.0 DESCRIPTION

3.1 Product information:

The HZA anchor channels consist of a C-shaped steel channel profile with serrated (toothed) channel lips with round headed anchors (HZA 38/23, 41/22, 41/27 and 53/34), I-shaped steel anchors (HZA 38/23 and 53/34), T-shaped steel anchors (HZA 38/23 and 53/34), or deformed reinforcing bars (HZA 38/23, 41/27 and 53/34). Round headed anchors are forged to the channel back. I- and T-shaped anchors and deformed reinforcing bars are factory welded to the channel back (as illustrated in [Figure B](#) of this report). The maximum number of anchors per channel is not limited. The HALFEN HZA anchor channels are made of carbon steel channel profiles, or stainless steel (HZA 38/23, 41/22 and 53/34 only) channel profiles. The anchor channels are shown in [Figure A](#) of this report. The available channel bolts feature a hammer-head and are shown in [Figure C](#). The combination of the HALFEN HZA anchor channels and the corresponding HZS channel bolts covered by this report are described in [Table 2](#) of this report. The appropriate channel bolts shall be placed in the anchor channel.

3.2 Material information:

Steel specifications for the channel profiles, anchors and channel bolts are given in [Table 9](#) of this report.

3.3 Concrete:

Normal-weight concrete shall comply with Section 5.2 of NZS 3101.

4.0 DESIGN AND INSTALLATION

4.1 Structure (Clause B1) - General:

The design strength of anchor channels under the 2021 NZBC, must be determined in accordance with Chapter 17 of NZS 3101, and this report.

4.1.1 Determination of forces acting on anchor channel: Anchor channels shall be designed for critical effects of factored loads (combinations of actions) as determined by elastic analysis taking into account the elastic support by anchors and the partial restraint of the channel ends by concrete compression stresses. As an alternative, the triangular load distribution method in accordance with Section 4.1.2 through 4.1.4 to calculate the tension and shear loads on anchors shall be permitted. Design of adjacent anchor channels shall be in accordance with Section 4.1.6.

4.1.2 Tension loads: The tension loads, $N_{ua,i}^a$, on an anchor due to a tension load, N_{ua} , acting on the channel shall be computed in accordance with Eq.(D-0.a). An example for the calculation of the tension loads acting on the anchors is given in [Figure 2](#).

$$N_{ua,i}^a = k \cdot A'_i \cdot N_{ua} \tag{D-0.a}$$

Where

A'_i = ordinate at the position of the anchor i assuming a triangle with the unit height at the position of load N_{ua} and the base length $2 \ell_{in}$ with ℓ_{in} determined in accordance with Eq. (D-0.c). An example is provided in [Figure 2](#).

$$k = 1/\sum A'_i \tag{D-0.b}$$

$$\ell_{in} = 4.93 \cdot (I_y)^{0.05} \cdot \sqrt{s} \geq s, \text{ in.} \tag{D-0.c}$$

$$\ell_{in} = 13 \cdot (I_y)^{0.05} \cdot \sqrt{s} \geq s, \text{ mm} \tag{D-0.c}$$

s = anchor spacing, in. (mm)

N_{ua} = factored tension load on anchor channel, lbf (N)

I_y = the moment of inertia of the channel shall be taken from [Table 1](#) of this report.

If several tension loads are simultaneously acting on the channel, a linear superimposition of the anchor forces for all loads shall be assumed.

If the exact position of the load on the channel is not known, the most unfavorable loading position shall be assumed for each failure mode (e.g. load acting over an anchor for the case of failure of an anchor by steel rupture or pull-out and load acting between anchors in the case of bending failure of the channel).

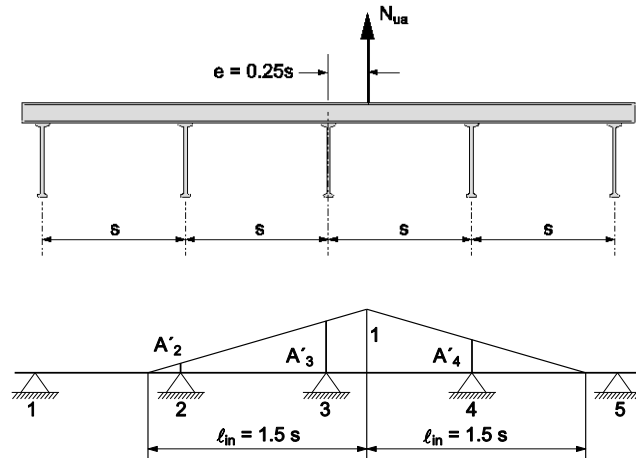

$$A'_2 = \frac{(\ell_{in} - s - e)}{\ell_{in}} = \frac{0.25s}{\ell_{in}} = \frac{1}{6}$$

$$N_{ua,1}^a = N_{ua,5}^a = 0$$

$$A'_3 = \frac{(\ell_{in} - e)}{\ell_{in}} = \frac{1.25s}{\ell_{in}} = \frac{5}{6}$$

$$N_{ua,2}^a = \frac{1}{6} \cdot \frac{2}{3} \cdot N_{ua} = \frac{1}{9} \cdot N_{ua}$$

$$A'_4 = \frac{(\ell_{in} - s + e)}{\ell_{in}} = \frac{0.75s}{\ell_{in}} = \frac{1}{2}$$

$$N_{ua,3}^a = \frac{5}{6} \cdot \frac{2}{3} \cdot N_{ua} = \frac{5}{9} \cdot N_{ua}$$

$$k = \frac{1}{A'_2 + A'_3 + A'_4} = \frac{2}{3}$$

$$N_{ua,4}^a = \frac{1}{2} \cdot \frac{2}{3} \cdot N_{ua} = \frac{1}{3} \cdot N_{ua}$$

FIGURE 2—EXAMPLE FOR THE CALCULATION OF ANCHOR FORCES IN ACCORDANCE WITH THE TRIANGULAR LOAD DISTRIBUTION METHOD FOR AN ANCHOR CHANNEL WITH FIVE ANCHORS. THE INFLUENCE LENGTH IS ASSUMED AS $\ell_{in} = 1.5s$ AND ECCENTRICITY AS $e = 0.25s$

4.1.3 Bending moment: The bending moment $M_{u,flex}$ on the channel due to tension loads acting on the channel shall be computed assuming a simply supported single span beam with a span length equal to the anchor spacing.

4.1.4 Shear loads:

4.1.4.1 Shear perpendicular to the channel axis: The shear load $V_{ua,y,i}^a$ on an anchor due to a shear load $V_{ua,y}$ acting on the channel perpendicular to its longitudinal axis shall be computed in accordance with Section 4.1.2 replacing N_{ua} in Eq. (D-0.a) by $V_{ua,y}$.

4.1.4.2 Shear longitudinal to the channel axis: The shear load $V_{ua,x,i}^a$ on an anchor due to a shear load $V_{ua,x}$ acting on the channel in direction of the longitudinal channel axis shall be computed as follows:

For the verification of the strength of the anchor channel for failure of the anchor or failure of the connection between anchor and channel, pryout failure and concrete edge failure in case of anchor channels arranged parallel to the edge without corner effects, the shear load $V_{ua,x}$ shall be equally distributed to all anchors for anchor channels with not more than three anchors or to three anchors for anchor channels with more than three anchors (as illustrated in Figure 3). The shear load $V_{ua,x}$ shall be distributed to those three that result in the most unfavorable design condition (in the example given in Figure 3 the shear load $V_{ua,x}$ shall be distributed to the anchors 10 to 12).

For verification of the strength of the anchor channel for concrete edge failure in case of anchor channels arranged perpendicular to the edge and in case of anchor channels arranged parallel to the edge with corner effects, the shear load $V_{ua,x}$, shall be equally distributed to all anchors for anchor channels with not more than three anchors, or to the three anchors closest to the edge or corner for anchor channels with more than three anchors (as illustrated in Figure 4).

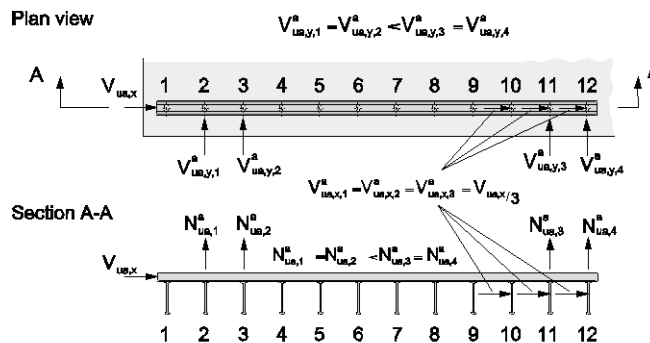

FIGURE 3—EXAMPLE FOR THE CALCULATION OF ANCHOR FORCES IN CASE OF ANCHOR CHANNELS WITH 12 ANCHORS LOADED IN SHEAR LONGITUDINAL TO THE CHANNEL AXIS FOR STEEL AND PRYOUT FAILURE

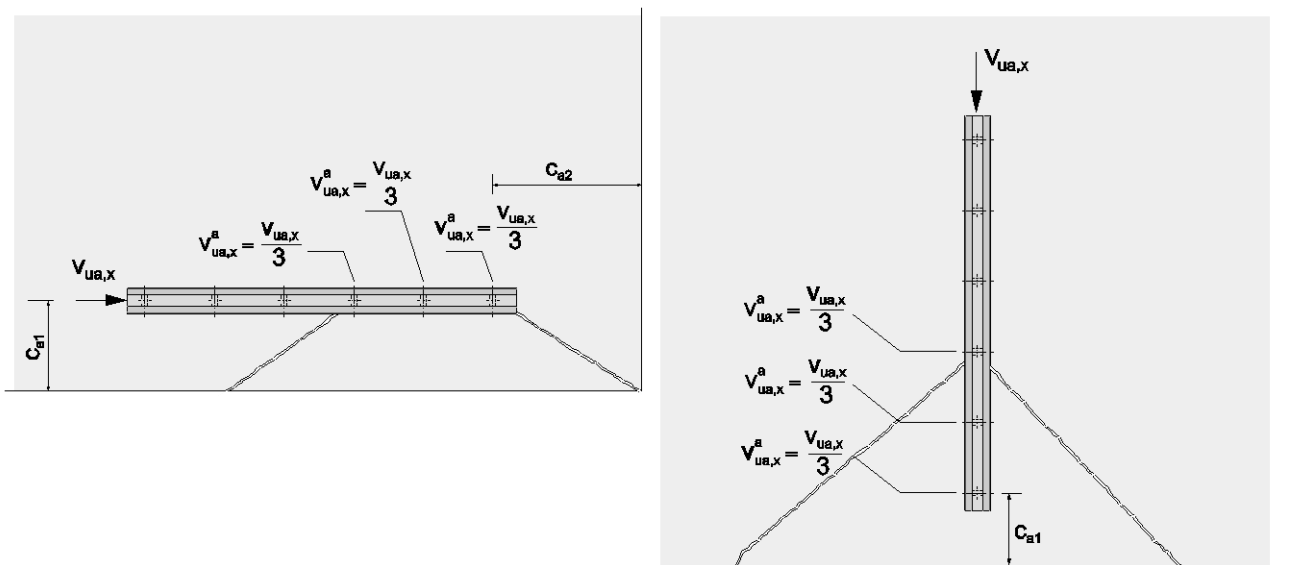

FIGURE 4—EXAMPLE FOR THE CALCULATION OF ANCHOR FORCES IN CASE OF ANCHOR CHANNELS WITH 6 ANCHORS LOADED IN SHEAR LONGITUDINAL TO THE CHANNEL AXIS FOR CONCRETE EDGE FAILURE

4.1.5 Forces related to anchor reinforcement: If tension loads are acting on the anchor channel, the factored tension forces of the anchor reinforcement for one anchor shall be computed for the factored tension load, $N_{ua,i}$, of the anchor assuming a strut-and-tie model.

If a shear load $V_{ua,y}$ is acting on the anchor channel, the resultant factored tension force of the anchor reinforcement $N_{ua,re}$, shall be computed by Eq.(D-0.d).

$$N_{ua,re} = V_{ua,y} ((e_s / z) + 1), \text{ lbf (N)} \quad \text{(D-0.d)}$$

where (as illustrated in [Figure 5](#)):

e_s = distance between reinforcement and shear force acting on the fixture, in. (mm)

z = internal lever arm of the concrete member, in. (mm)

$z = 0.85 h'$

$= 0.85 (h - h_{ch} - 0.5 d_a)$

$$\leq \min \left\{ \begin{matrix} 2h_{ef} \\ 2c_{a1} \end{matrix} \right\}$$

h' see [Figure 5](#)

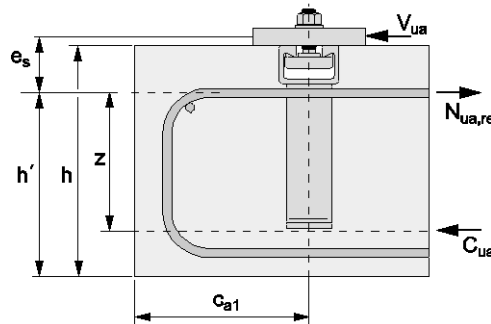
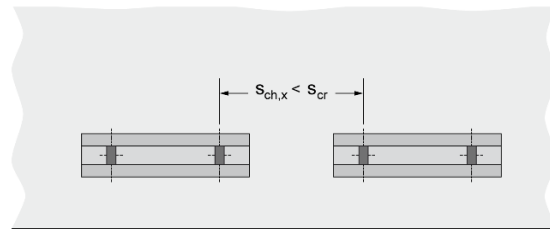
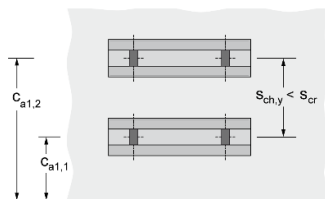

FIGURE 5—ANCHOR REINFORCEMENT TO RESIST SHEAR LOADS

4.1.6 Adjacent anchor channels: Anchor channels may be arranged as shown in [Figure 6](#). Adjacent anchor channels must be of same size and consist of anchors with same type and embedment depth. In case of anchor channel configurations according to [Figure 6b](#)) and 6c) loaded in shear in any direction, the load shall be transferred to the adjacent anchor channels by a single plate ([Figure 7](#)).



a) Anchor channels in linear arrangement



b) Anchor channels arranged parallel to edge ($n_1=2$)

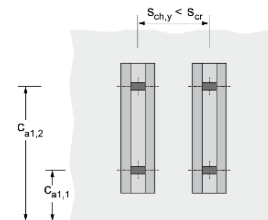

c) Anchor channels arranged perpendicular to edge ($n_1=2$)

FIGURE 6—INCLUDED CONFIGURATIONS OF ADJACENT ANCHOR CHANNELS

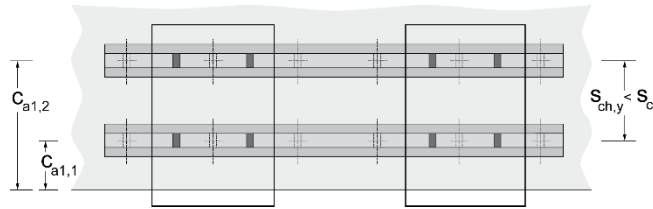

FIGURE 7—PERMISSIBLE CONFIGURATION WITH MULTIPLE ATTACHMENTS ($n_1 = 2$); TWO PLATES SHOWN. SHEAR TRANSFER BETWEEN ADJACENT ANCHOR CHANNELS BY ADJACENT PLATES.

4.2 Structure (Clause B1) - Design of anchor channels:

4.2.1 General: The design strength of anchor channels under the 2021 NZBC shall be determined in accordance with Chapter 17 of NZS 3101 and this report.

Design parameters in this report and references to NZS 3101 are based on the 2021 NZBC unless noted otherwise in this section and through 4.2.10 of this report.

The strength design shall comply with Section 17.5.4 of NZS 3101, except as required in Section 17.6 of NZS 3101, as applicable.

Design parameters are provided in [Tables 1](#) through [10](#) of this report. Strength reduction factors, ϕ , as given in the tables of this report shall be used for combinations of actions set out in AS/NZS 1170 for the ultimate limit state as noted in Section 17.5.2 of NZS 3101.

In 17-1 and Eq. 17-2 of NZS 3101, ϕN_n and $\phi V_{n,y}$ are the lowest design strengths determined from all appropriate failure modes. ϕN_n is the lowest design strength in tension of an anchor channel determined from consideration of ϕN_{sa} , ϕN_{sc} , ϕN_{sl} , ϕN_{ss} , $\phi M_{s,flex}$, ϕN_{cb} , (anchor channels without anchor reinforcement to take up tension loads) or ϕN_{ca} (anchor channels with anchor reinforcement to take up tension loads), ϕN_{pn} and ϕN_{sb} . $\phi V_{n,y}$ is the lowest design strength in shear perpendicular to the axis of an anchor channel as determined from $\phi V_{sa,y}$, $\phi V_{sc,y}$, ϕV_{ss} , $\phi V_{ss,M}$, $\phi V_{sl,y}$, $\phi V_{cb,y}$ (anchor channels without anchor reinforcement to take up shear loads perpendicular to the channel axis), or $\phi V_{ca,y}$ (anchor channels with anchor reinforcement to take up shear loads perpendicular to the channel axis) and $\phi V_{cp,y}$. $\phi V_{n,x}$ is the lowest design strength in shear acting longitudinal to the channel axis of an anchor channel as determined from $\phi V_{sa,x}$, $\phi V_{sc,x}$, ϕV_{ss} , $\phi V_{ss,M}$, $\phi V_{sl,x}$, $\phi V_{cb,x}$, (anchor channel without anchor reinforcement to take up shear loads), or $\phi V_{ca,x}$ (anchor channel with anchor reinforcement to take up shear loads) and $\phi V_{cp,x}$. The design strength for all anchors of an anchor channel shall be determined.

4.2.2 Tension loads:

4.2.2.1 General: Following verifications are required:

- a) Steel failure: Steel strength of anchor, strength of connection between anchor and channel, strength for local failure of channel lip, strength of channel bolt, bending strength of channel, see Section 4.2.2.2.
- b) Concrete breakout strength of anchor in tension, see Section 4.2.2.3.
- c) Pullout strength of anchor channel in tension, see Section 4.2.2.4.
- d) Concrete side-face blow-out strength of anchor channels in tension, see Section 4.2.2.5.

4.2.2.2 Steel strength in tension: The nominal strength, N_{sa} , of a single anchor shall be taken from [Table 3](#) of this report.

The nominal strength, N_{sc} , of the connection between anchor and anchor channel shall be taken from [Table 3](#) of this report.

The nominal strength of the channel lips to take up tension loads transmitted by a channel bolt, N_{sl} , shall be taken from [Table 3](#) of this report. This value is valid only if the center-to-center distance between the channel bolts under consideration and adjacent channel bolts, S_{chb} , is at least $2b_{ch}$. If this requirement is not met, then the value N_{sl} given in [Table 3](#) shall be reduced by the factor:

$$1 + \sum_{i=2}^{n+1} \left[\left(1 - \frac{S_{chb,i}}{2b_{ch}} \right)^2 \cdot \frac{N_{ua,i}^b}{N_{ua,1}^b} \right] \tag{D-3.a}$$

Where the center-to-center spacing between channel bolts shall not be less than 3-times the bolt diameter, d_s .

b_{ch} = channel width, taken from [Table 1](#), in. (mm)

The nominal strength of the channel bolt, N_{ss} , shall be taken from [Table 7](#) of this report.

The nominal bending strength of the anchor channel, $M_{s,flex}$, shall be taken from [Table 3](#) of this report.

4.2.2.3 Concrete breakout strength in tension: The nominal concrete breakout strength, N_{cb} , of a single anchor in tension of an anchor channel shall be determined in accordance with Eq. (D-4.a)

$$N_{cb} = N_b \cdot \psi_{s,N} \cdot \psi_{ed,N} \cdot \psi_{co,N} \cdot \psi_{c,N} \cdot \psi_{cp,N}, \text{ lbf (N)} \quad (D-4.a)$$

Where anchors consist of deformed reinforcing bars and the minimum spacing requirement in [Table 1](#) is met, verification for concrete breakout is not required provided that the reinforcing bars are lap sliced with reinforcing bars in the member according to the requirements of Section 8.7 of NZS 3101.

The basic concrete breakout strength of a single anchor in tension in cracked concrete, N_b , shall be determined in accordance with Eq. (D-7.a).

$$N_b = 24 \cdot \lambda \cdot \alpha_{ch,N} \cdot (f_c)^{0.5} \cdot h_{ef}^{1.5}, \text{ lbf} \quad (D-7.a)$$

$$N_b = 10 \cdot \lambda \cdot \alpha_{ch,N} \cdot (f_c)^{0.5} \cdot h_{ef}^{1.5}, \text{ N} \quad (D-7.a)$$

where

$$\lambda = 1 \quad (\text{normal-weight concrete})$$

$$\alpha_{ch,N} = (h_{ef} / 7.1)^{0.15} \leq 1.0, \text{ (inch-pound units)} \quad (D-7.b)$$

$$\alpha_{ch,N} = (h_{ef} / 180)^{0.15} \leq 1.0, \text{ (SI-units)} \quad (D-7.b)$$

The modification factor to account for the influence of location and loading of adjacent anchors, $\psi_{s,N}$, shall be computed in accordance with Eq. (D-9.a)

$$\psi_{s,N} = \frac{1}{1 + \sum_{i=2}^{n+1} \left[\left(1 - \frac{s_i}{s_{cr,N}} \right)^{1.5} \cdot \frac{N_{ua,i}^a}{N_{ua,1}^a} \right]} \quad (D-9.a)$$

where (as illustrated in [Figure 8](#)):

s_i = distance between the anchor under consideration and adjacent anchor, in. (mm)

$$\leq s_{cr,N}$$

$$s_{cr,N} = 2 (2.8 - (1.3 h_{ef} / 7.1)) h_{ef} \geq 3 h_{ef}, \text{ in.} \quad (D-9.b)$$

$$s_{cr,N} = 2 (2.8 - (1.3 h_{ef} / 180)) h_{ef} \geq 3 h_{ef}, \text{ mm} \quad (D-9.b)$$

$N_{ua,i}^a$ = factored tension load of an influencing anchor, lbf (N)

$N_{ua,1}^a$ = factored tension load of the anchor under consideration, lbf (N)

N = number of anchors of all anchor channels within a radial distance $s_{cr,N}$ from the anchor under consideration

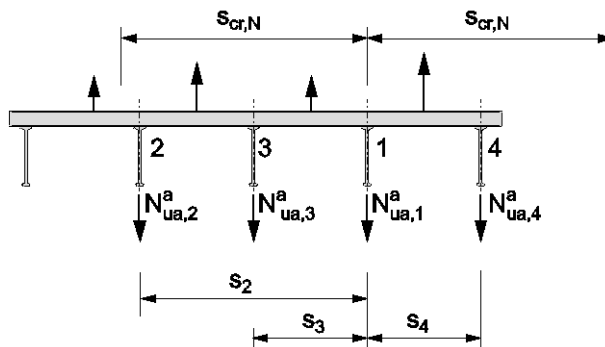

1 = anchor under consideration,
2 to 4 = influencing anchors

FIGURE 8—EXAMPLE OF ANCHOR CHANNEL WITH NON-UNIFORM ANCHOR TENSION FORCES

The modification factor for edge effect of anchors loaded in tension, $\psi_{ed,N}$, shall be computed in accordance with Eq. (D-10.a) or (D-10.b).

If $c_{a1} \geq c_{cr,N}$
 then $\psi_{ed,N} = 1.0$ (D-10.a)

If $c_{a1} < c_{cr,N}$
 then $\psi_{ed,N} = (c_{a1} / c_{cr,N})^{0.5} \leq 1.0$ (D-10.b)

where

$c_{cr,N} = 0.5 s_{cr,N}$
 $= (2.8 - (1.3 h_{ef} / 7.1)) h_{ef} \geq 1.5 h_{ef}$, in. (D-11.a)

$c_{cr,N} = 0.5 s_{cr,N}$
 $= (2.8 - (1.3 h_{ef} / 180)) h_{ef} \geq 1.5 h_{ef}$, mm (D-11.a)

If anchor channels are located in a narrow concrete member with multiple edge distances $c_{a1,1}$ and $c_{a1,2}$ (as shown in Figure 9b), the minimum value of $c_{a1,1}$ and $c_{a1,2}$ shall be inserted in Eq. (D-10.b).

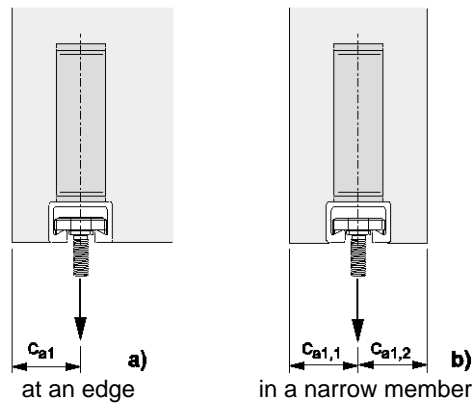

FIGURE 9—ANCHOR CHANNELS WITH EDGE(S)

The modification factor for corner effect for anchors loaded in tension (as illustrated in Figures 10a), $\psi_{co,N}$, shall be computed in accordance with Eq. (D-11.b) or (D-11.c)

If $c_{a2} \geq c_{cr,N}$
 then $\psi_{co,N} = 1.0$ (D-11.b)

If $c_{a2} < c_{cr,N}$
 then $\psi_{co,N} = (c_{a2} / c_{cr,N})^{0.5} \leq 1.0$ (D-11.c)

where

c_{a2} = distance of the anchor under consideration to the corner (see Figure 10 a, b, d)

If an anchor is influenced by two corners (as illustrated in Figure 10c), the factor $\psi_{co,N}$ shall be computed for each of the values $c_{a2,1}$ and $c_{a2,2}$ and the product of the factors, $\psi_{co,N}$, shall be inserted in Eq. (D-4.a).

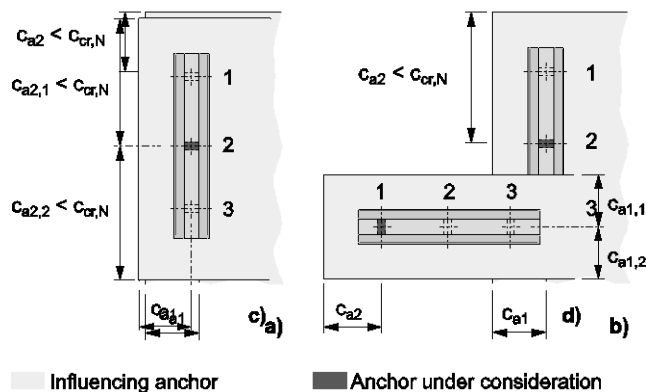

FIGURE 10—ANCHOR CHANNEL AT A CORNER OF A CONCRETE MEMBER

For anchor channels located in a region of a concrete member where analysis indicates no cracking at service load levels, the following modification factor shall be permitted:

$$\psi_{c,N} = 1.25.$$

Where analysis indicates cracking at service load levels, $\psi_{c,N}$ shall be taken as 1.0. The cracking in the concrete shall be controlled by flexural reinforcement distributed in accordance with Section 2.4.4.4 of NZS 3101, or equivalent crack control shall be provided by confining reinforcement.

The modification factor for anchor channels designed for uncracked concrete without supplementary reinforcement to control splitting, $\psi_{cp,N}$, shall be computed in accordance with Eq. (D-12.a) or (D-13.a). The critical edge distance, c_{ac} , shall be taken from [Table 4](#) of this report.

If $c_{a,min} \geq c_{ac}$
 then $\psi_{cp,N} = 1.0$ (D-12.a)

If $c_{a,min} < c_{ac}$
 then $\psi_{cp,N} = c_{a,min} / c_{ac}$ (D-13.a)

whereby $\psi_{cp,N}$ as determined in accordance with Eq. (D-13.a) shall not be taken less than $c_{cr,N} / c_{ac}$ with $c_{cr,N}$ taken from Eq. (D-11.a). For all other cases, $\psi_{cp,N}$ shall be taken as 1.0.

Where anchor reinforcement is developed in accordance with Chapter 8 of NZS 3101 on both sides of the breakout surface for an anchor of an anchor channel, the design strength of the anchor reinforcement, ϕN_{ca} , shall be permitted to be used instead of the concrete breakout strength, ϕN_{cb} , in determining ϕN_n . The anchor reinforcement for one anchor shall be designed for the tension force, N_{ua} , on this anchor using a strut-and-tie model. The provisions in [Figure 11](#) shall be taken into account when sizing and detailing the anchor reinforcement. Anchor reinforcement shall consist of stirrups made from deformed reinforcing bars with a maximum diameter of $5/8$ in. (No. 5 bar) (16 mm). A strength reduction factor ϕ of 0.75 shall be used in the design of the anchor reinforcement.

For anchor channels located parallel to the edge of a concrete member or in a narrow concrete member, the plane of the anchor reinforcement shall be arranged perpendicular to the longitudinal axis of the channel (as shown in [Figure 11](#) a, b).

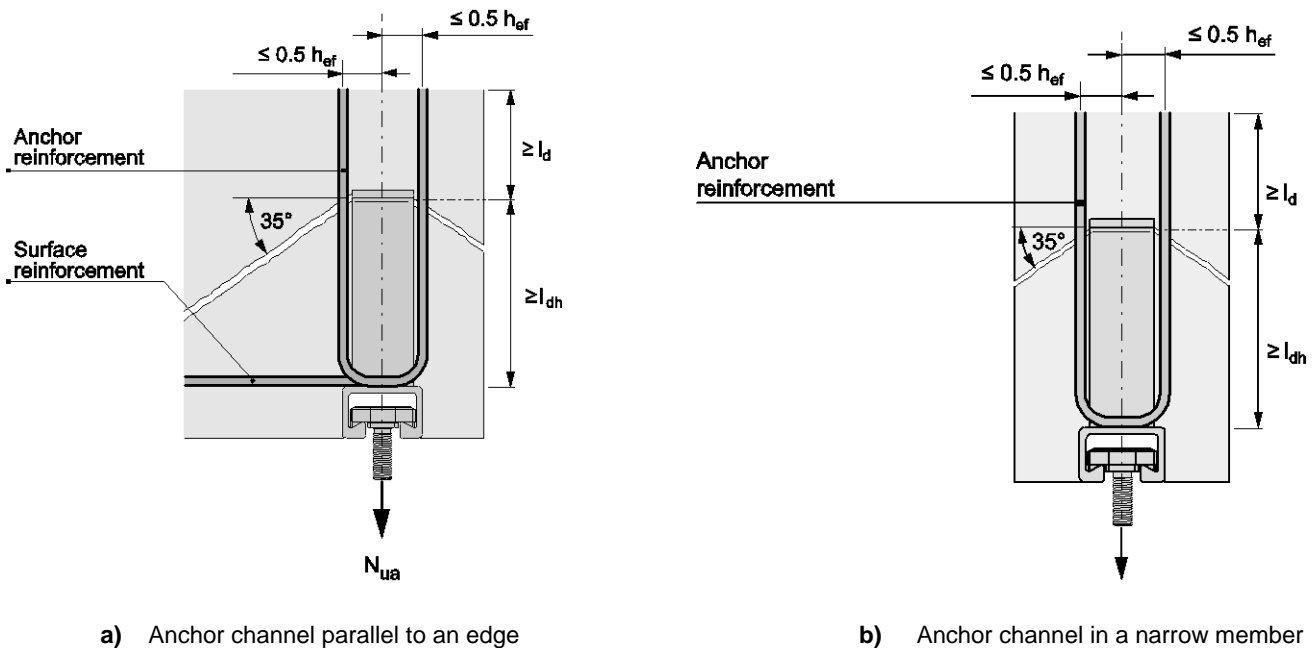

FIGURE 11—ARRANGEMENT OF ANCHOR REINFORCEMENT FOR ANCHOR CHANNELS LOADED BY TENSION LOAD

4.2.2.4 Pullout strength in tension: For anchors of anchor channels, the pullout strength N_{pn} shall be computed in accordance with Section 17.5.7.3 of NZS 3101.

4.2.2.5 Concrete side-face blowout strength in tension: For anchor channels with deep embedment close to an edge ($h_{ef} > 2.0 c_{a1}$) the nominal side-face blowout strength, N_{sb} , of a single anchor shall be computed. This verification is not required for all anchor channels of this report.

4.2.3 Shear loads acting perpendicular to the channel axis:

4.2.3.1 General: Following verifications are required:

- Steel failure: Strength of channel bolt, strength for local failure of channel lip, strength of connection between anchor and channel profile and strength of anchor, see Section 4.2.3.2
- Concrete edge breakout strength of anchor channel in shear, see Section 4.2.3.3
- Concrete pryout strength of anchor channel in shear, see Section 4.2.3.4

4.2.3.2 Steel strength of anchor channels in shear: For anchor channels, the nominal steel shear strength shall be determined as follows:

The nominal strength of a channel bolt in shear, V_{ss} , must be taken from [Table 8](#) of this report.

If the fixture is not clamped against the concrete but secured to the channel bolt at a distance from the concrete surface (e.g. by double nuts), the nominal strength of a channel bolt in shear, $V_{ss,M}$, shall be computed in accordance with Eq. (D-20.b).

$$V_{ss,M} = (\alpha_M \cdot M_{ss}) / l, \text{ lbf (N)} \quad (\text{D-20.b})$$

where

α_M = factor to take account of restraint of the fixture
 = 1.0 if the fixture can rotate freely (no restraint)
 = 2.0 if the fixture cannot rotate (full restraint)

$$M_{ss} = M_{ss}^0 \cdot \left(1 - \frac{N_{ua}}{\phi N_{ss}} \right), \text{ lbf-in. (Nm)} \quad (\text{D-20.c})$$

M_{ss}^0 = nominal flexural strength of channel bolt. It shall be taken from [Table 8](#) of this report

$$\leq 0.5 \cdot N_{sl} \cdot a$$

$$\leq 0.5 \cdot N_{ss} \cdot a$$

l = lever arm, in. (mm)

a = internal lever arm, in. (mm)

The nominal strength of the channel lips to take up shear loads perpendicular to the channel axis transmitted by a channel bolt, $V_{sl,y}$, shall be taken from [Table 5](#) of this report.

The nominal strength of one anchor, $V_{sa,y}$, to take up shear loads perpendicular to the channel axis shall be taken from [Table 5](#) of this report.

The nominal strength of the connection between one anchor and the anchor channel, $V_{sc,y}$, to take up shear loads perpendicular to the channel axis shall be taken from [Table 5](#) of this report.

4.2.3.3 Concrete breakout strength of an anchor channel in shear perpendicular to the channel axis:

The nominal concrete breakout strength, $V_{cb,y}$, in shear perpendicular to the channel axis of a single anchor of an anchor channel in cracked concrete shall be computed as follows:

- For a shear force perpendicular to the edge, by Eq. (D-21.a)

$$V_{cb,y} = V_b \cdot \psi_{s,V} \cdot \psi_{co,V} \cdot \psi_{c,V} \cdot \psi_{h,V}, \text{ lbf (N)} \quad (\text{D-21.a})$$

- For a shear force parallel to an edge (as shown in [Figure 12](#)), $V_{cb,y}$, shall be permitted to be 2.5 times the value of the shear force determined from Eq. (D-21.a) with the shear force assumed to act perpendicular to the edge.

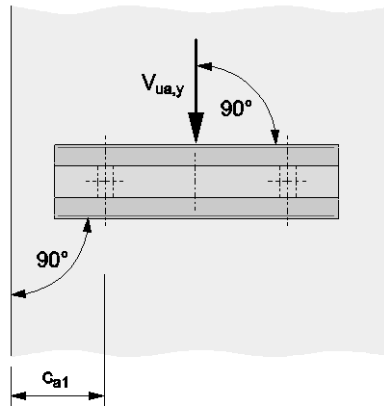

FIGURE 12 — ANCHOR CHANNEL ARRANGED PERPENDICULAR TO THE EDGE AND LOADED PARALLEL TO THE EDGE

The basic concrete breakout strength in shear perpendicular to the channel axis of a single anchor of an anchor channel in cracked concrete, V_b , shall be computed in accordance with Eq. (D-24.a).

$$V_b = \lambda \cdot \alpha_{ch,V} \cdot (f'_c)^{0.5} \cdot c_{a1}^{4/3}, \text{ lbf (N)} \quad \text{(D-24.a)}$$

where

$\lambda = 1$ (normal-weight concrete)

$\alpha_{ch,V}$ = shall be taken from [Table 6](#) of this report.

f'_c = the lesser of the specified concrete compressive strength and 8,500 psi (58.6 MPa)

The modification factor to account for the influence of location and loading of adjacent anchors, $\psi_{s,V}$ shall be computed in accordance with Eq. (D-24.b).

$$\psi_{s,V} = \frac{1}{1 + \sum_{i=2}^{n+1} \left[\left(1 - \frac{s_i}{s_{cr,V}} \right)^{1.5} \cdot \frac{V_{ua,y,i}^a}{V_{ua,y,1}^a} \right]} \quad \text{(D-24.b)}$$

where (as illustrated in [Figure 13](#)):

s_i = distance between the anchor under consideration and the adjacent anchor, in. (mm)

$$\leq s_{cr,V}$$

$$s_{cr,V} = 4c_{a1} + 2b_{ch}, \text{ in. (mm)} \quad \text{(D-24.c)}$$

$V_{ua,y,i}^a$ = factored shear load of an influencing anchor, lbf (N),

$V_{ua,y,1}^a$ = factored shear load of the anchor under consideration, lbf (N),

n = number of anchors of all anchor channels within a radial distance $s_{cr,V}$ from the anchor under consideration

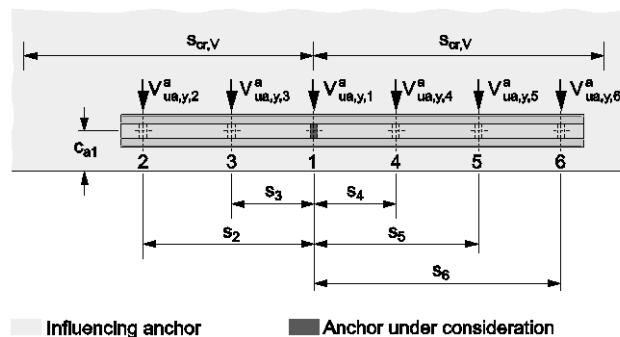

FIGURE 13—EXAMPLE OF AN ANCHOR CHANNEL WITH DIFFERENT ANCHOR SHEAR FORCES

The modification factor for corner effect for an anchor loaded in shear perpendicular to the channel axis (as shown in [Figure 14a](#)), $\psi_{co,V}$, shall be computed in accordance with Eq. (D-24.d) or (D-24.e).

If $c_{a2} \geq c_{cr,V}$
 then $\psi_{co,V} = 1.0$ (D-24.d)

If $c_{a2} < c_{cr,V}$
 then $\psi_{co,V} = (c_{a2} / c_{cr,V})^{0.5}$ (D-24.e)

where

$c_{cr,V} = 2c_{a1} + b_{ch}$, in. (mm) (D-24.f)

If an anchor is influenced by two corners (as shown in [Figure 14b](#)), then the factor $\psi_{co,V}$ shall be computed for each corner in accordance with Eq. (D-24.d) or (D-24.e) and the product of the values of $\psi_{co,V}$ shall be inserted in Eq. (D-21.a).

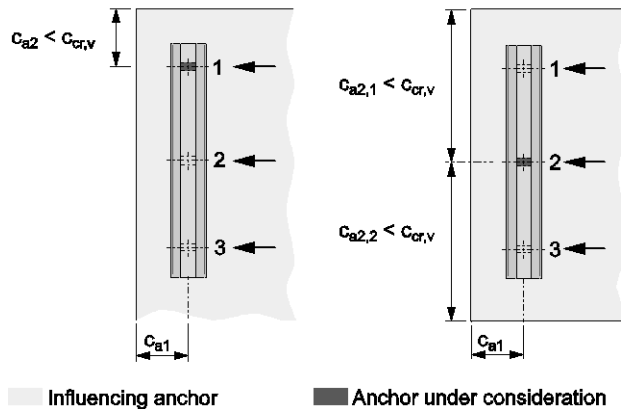

**FIGURE 14—EXAMPLE OF AN ANCHOR CHANNEL LOADED IN SHEAR WITH ANCHORS,
 LEFT: INFLUENCED BY ONE CORNER
 RIGHT: INFLUENCED BY TWO CORNERS**

For anchor channels located in a region of a concrete member where analysis indicates no cracking at service load levels, the following modification factor shall be permitted:

$\psi_{c,V} = 1.4$.

For anchor channels located in a region of a concrete member where analysis indicates cracking at service load levels, the following modifications shall be permitted:

$\psi_{c,V} = 1.0$ for anchor channels in cracked concrete with no supplementary reinforcement.

$\psi_{c,V} = 1.2$ for anchor channels in cracked concrete with edge reinforcement of a No. 4 bar (12.7 mm) or greater between the anchor channel and the edge in accordance with [Figure 15](#).

$\psi_{c,V} = 1.4$ for anchor channels in cracked concrete containing edge reinforcement with a diameter of 1/2 inch (12.7 mm) or greater (No. 4 bar or greater) between the anchor channel and the edge, and with the edge reinforcement enclosed within stirrups with a diameter of 1/2 inch (12.7 mm) or greater (No. 4 bar or greater) spaced at 8 inches (200 mm) maximum.

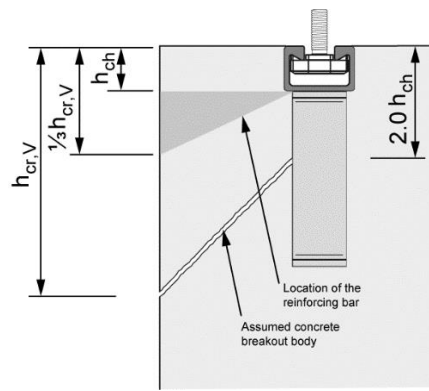

FIGURE 15—RECOMMENDED AREA FOR THE LOCATION OF THE EDGE REINFORCEMENT BAR
 (Reinforcing bar location within recommended area shall account for all factors, (for example, concrete cover, bend radius, etc.) as required by NZS 3101)

The modification factor for anchor channels located in a concrete member with $h < h_{cr,V}$, $\psi_{h,V}$ (an example is given in Figure 16), shall be computed in accordance with Eq. (D-29.a).

$$\psi_{h,V} = (h / h_{cr,V})^{1/2} \leq 1.0 \quad (D-29.a)$$

where

$$h_{cr,V} = 2c_{a1} + 2h_{ch}, \text{ in. (mm)} \quad (D-29.b)$$

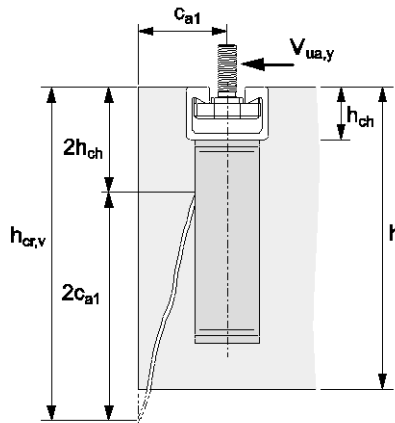

FIGURE 16—EXAMPLE OF AN ANCHOR CHANNEL IN A MEMBER WITH A THICKNESS $h < h_{cr,V}$

Where an anchor channel is located in a narrow member ($c_{a2,max} < c_{cr,V}$) with a thickness $h < h_{cr,V}$ (see Figure 17), the edge distance c_{a1} in Eq. (D-24.a), (D-24.c), (D-24.f) and (D-29.b) shall not exceed the value $c_{a1,red}$ determined in accordance with Eq. (D-29.c).

$$c_{a1,red} = \max \left[\frac{c_{a,max} - b_{ch}}{2}; \frac{h - 2h_{ch}}{2} \right], \text{ in. (mm)} \quad (D-29.c)$$

where $c_{a2,max}$ is the largest of the edge distances perpendicular to the longitudinal axis of the channel.

For this example, the value of $c_{a1,red}$ is obtained by moving the failure surface forward until it intersects the corner as shown.

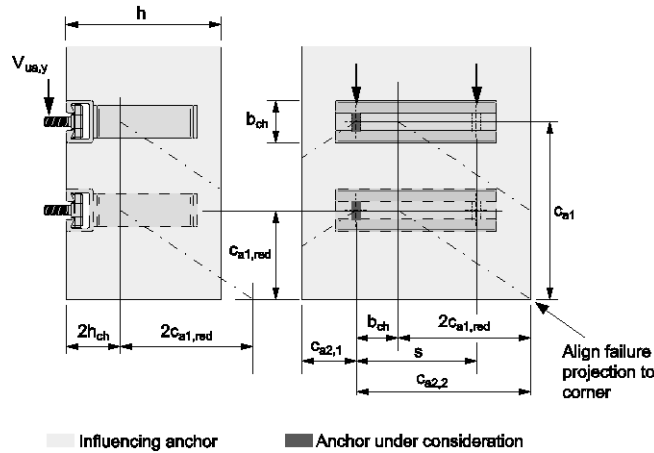

FIGURE 17—EXAMPLE OF AN ANCHOR CHANNEL INFLUENCED BY TWO CORNERS AND MEMBER THICKNESS (IN THIS EXAMPLE $c_{a2,2}$ IS DECISIVE FOR THE DETERMINATION OF $c_{a1,red}$)

For anchor channels with b_{ch} greater than 1.1 in. (28 mm) and h_{ch} greater than 0.6 in. (15 mm) arranged parallel to the edge and loaded by a shear load perpendicular to the edge and anchor reinforcement developed in accordance with Chapter 8 of NZS 3101 on both sides of the concrete surface, the design strength of the anchor reinforcement, $\phi V_{ca,y}$, shall be permitted to be used instead of the concrete breakout strength, $\phi V_{cb,y}$, in determining $\phi V_{n,y}$.

A strength reduction factor ϕ of 0.75 shall be used in the design of the anchor reinforcement. The strength of the anchor reinforcement assumed in design shall not exceed the value in accordance with Eq. (D-29.d). Only anchor reinforcement that complies with Figure 18 shall be assumed as effective.

The maximum strength of the anchor reinforcement $V_{ca,y,max}$ of a single anchor of an anchor channel shall be computed in accordance with Eq. (D-29.d).

$$V_{ca,y,max} = 2.85 / (c_{a1})^{0.12} \cdot V_{cb,y}, \text{ lbf} \quad (\text{D-29.d})$$

$$V_{ca,y,max} = 4.20 / (c_{a1})^{0.12} \cdot V_{cb,y}, \text{ N} \quad (\text{D-29.d})$$

where $V_{cb,y}$ is determined in accordance with Eq. (D-21.a).

Anchor reinforcement shall consist of stirrups made from deformed reinforcing steel bars with a maximum diameter of $5/8$ in. (16 mm) (No. 5 bar) and straight edge reinforcement with a diameter not smaller than the diameter of the stirrups (as shown in Figure 18). Only one bar at both sides of each anchor shall be assumed as effective. The distance of this bar from the anchor shall not exceed $0.5c_{a1}$ and the anchorage length in the breakout body shall be not less than 4 times the bar diameter. The distance between stirrups shall not exceed the smaller of anchor spacing or 6 in. (152 mm).

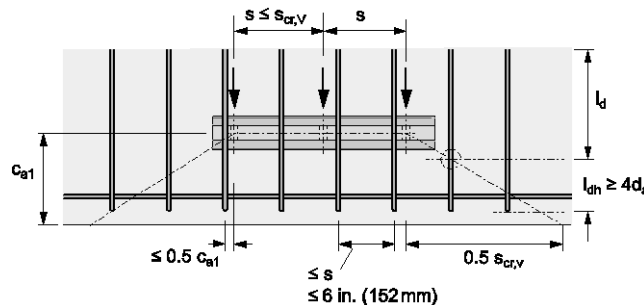

FIGURE 18—REQUIREMENTS FOR DETAILING OF ANCHOR REINFORCEMENT OF ANCHOR CHANNELS

The anchor reinforcement of an anchor channel shall be designed for the highest anchor load, $V_{ua,y}^e$ of all anchors but at least for the highest individual shear load, $V_{ua,y}^b$ acting on the channel. This anchor reinforcement shall be arranged at all anchors of an anchor channel.

For anchor channels in a parallel configuration, it shall be permitted to calculate the concrete breakout strength either for the anchor channel closest to the edge or the anchor channel furthest from the edge. The nominal concrete breakout strength shall be computed as follows:

- a) For verification of the anchor channel closest to the edge, the nominal concrete breakout strength shall be calculated according to Eq. (D-29.e).

$$V_{cb} = \min(n_{ch} \cdot V_{cb}(c_{a1,1}); V_{cb}(c_{a1,n_1})), \quad \text{lb f} \quad (\text{D-29.e})$$

- b) For verification of the anchor channel furthest from the edge, the nominal concrete breakout strength shall be calculated according to Eq. (D-29.f).

$$V_{cb} = V_{cb}(c_{a1,n_1}), \quad \text{lb f} \quad (\text{D-29.f})$$

For case b, the anchor channels closer to the edge shall be assumed to carry zero tension and shear load.

4.2.3.4 Concrete pryout strength of anchor channels in shear perpendicular to the channel axis: The nominal pryout strength, V_{cp} , in shear of a single anchor of an anchor channel without anchor reinforcement shall be computed in accordance with Eq. (D-30.a).

$$V_{cp} = V_{cp,x} = V_{cp,y} = k_{cp} N_{cb}, \quad \text{lb f (N)} \quad (\text{D-30.a})$$

where

k_{cp} = factor taken from [Table 6](#) of this report

N_{cb} = nominal concrete breakout strength of the anchor under consideration, lb f (N), determined in accordance with 4.2.2.3; however in the determination of the modification factor $\psi_{s,N}$, the values $N_{ua,1}^a$ and $N_{ua,i}^a$ in Eq. (D-9.a) shall be replaced by $V_{ua,y,1}^a$ and $V_{ua,y,i}^a$, respectively.

The nominal pryout strength, V_{cp} , in shear of a single anchor of an anchor channel with anchor reinforcement shall not exceed.

$$V_{cp} = V_{cp,x} = V_{cp,y} = 0.75 \cdot k_{cp} \cdot N_{cb}, \quad \text{lb f (N)} \quad (\text{D-31.a})$$

where k_{cp} and N_{cb} as defined above.

4.2.4 Shear loads acting longitudinal to the channel axis:

4.2.4.1 General: Following verifications are required:

- Steel failure: Strength of channel bolt, strength for local failure of channel lip, strength of connection between anchor and channel profile and strength of anchor, see Section 4.2.4.2.
- Concrete edge breakout strength of anchor channel in shear, see Section 4.2.4.3.
- Concrete pryout strength of anchor channel in shear, see Section 4.2.4.4.

4.2.4.2 Steel strength of anchor channels in shear: For anchor channels, the nominal steel shear strength shall be determined as follows:

The nominal strength of a channel bolt in shear, V_{ss} , shall be taken from [Table 8](#) of this report.

If the fixture is not clamped against the concrete but secured to the channel bolt at a distance from the concrete surface (e.g. by double nuts), the nominal strength of a channel bolt in shear, $V_{ss,M}$, shall be computed in accordance with Eq. (D-20.b).

The nominal strength of the channel lips to take up shear loads in direction of the longitudinal channel axis transmitted by a channel bolt, $V_{sl,x}$, shall be taken from [Table 5](#) of this report.

The nominal strength of one anchor, $V_{sa,x}$, to take up shear loads perpendicular to the channel axis shall be taken from [Table 5](#) of this report.

The nominal strength of the connection between one anchor and the anchor channel, $V_{sc,x}$, to take up shear loads longitudinal to the channel axis shall be taken from [Table 5](#) of this report.

4.2.4.3 Concrete breakout strength of an anchor channel in shear: The nominal concrete breakout strength, $V_{cb,x}$, in shear in direction of the longitudinal channel axis of a single anchor of an anchor channel in cracked concrete shall be computed as follows:

- a) For a shear force perpendicular to the edge, by Eq. (D-21.a). The basic concrete breakout strength in shear in direction of the longitudinal channel axis of a single anchor of an anchor channel in cracked concrete, V_b , shall be computed in accordance with Eq. (D-24.a).
- b) For a shear force parallel to an edge, $V_{cb,x}$, shall be permitted to be 2 times the value of the shear force determined from Eq. (D-21.a) with the shear force assumed to act perpendicular to the edge.

4.2.4.4 Concrete pryout strength in shear: The nominal pryout strength, $V_{cp,x}$, in shear of a single anchor of an anchor channel without anchor reinforcement shall be computed in accordance with Eq. (D-30.a).

The nominal pryout strength, $V_{cp,x}$, in shear of a single anchor of an anchor channel with anchor reinforcement shall not exceed Eq. (D-31.a).

4.2.5 Requirements for seismic design: Anchor channels shall be designed according to 17.6.1 (a), (b), and (c) of NZS 3101.

For seismic design of anchor channels the design strengths given in Section 4.2.1 through Section 4.2.4 shall be taken as the corresponding seismic strengths $\phi N_{n,seis}$, $\phi V_{n,y,seis}$ and $\phi V_{n,x,seis}$.

4.2.6 Interaction of tensile and shear forces: For designs that include combined tensile and shear forces, the interaction of these loads has to be verified.

Anchor channels subjected to combined axial and shear loads shall be designed to satisfy the following requirements by distinguishing between steel failure of the channel bolt, steel failure modes of the anchor channel and concrete failure modes.

4.2.6.1 Steel failure of channel bolts under combined loads: For channel bolts, Eq. (D-32.a) shall be satisfied

$$\left(\frac{N_{ua}^b}{\phi N_{ss}}\right)^2 + \left(\frac{V_{ua}^b}{\phi V_{ss}}\right)^2 \leq 1.0 \quad (\text{D-32.a})$$

$$\text{with } V_{ua}^b = \sqrt{(V_{ua,x}^b)^2 + (V_{ua,y}^b)^2}$$

where N_{ua}^b is the factored tension load, $V_{ua,y}^b$ is the factor shear load in perpendicular direction, and $V_{ua,x}^b$ is the factored shear load in longitudinal direction to the channel axis on the channel bolt under consideration.

This verification is not required in case of shear load with lever arm as Eq. (D-20.b) accounts for the interaction.

4.2.6.2 Steel failure modes of anchor channels under combined loads: For steel failure modes of anchor channels Eq. (D-32.b), (D-32.c) and (D-32.d) shall be satisfied.

a) For anchor and connection between anchor and channel profile:

$$\begin{aligned} & \max\left(\frac{N_{ua}^a}{\phi N_{sa}}; \frac{N_{ua}^a}{\phi N_{sc}}\right)^\alpha + \max\left(\frac{V_{ua,y}^a}{\phi V_{sa,y}}; \frac{V_{ua,y}^a}{\phi V_{sc,y}}\right)^\alpha \\ & + \max\left(\frac{V_{ua,x}^a}{\phi V_{sa,x}}; \frac{V_{ua,x}^a}{\phi V_{sc,x}}\right)^2 \leq 1.0 \end{aligned} \quad (\text{D-32.b})$$

where

$\alpha = 2$ for anchor channels with

$$\max(V_{sa,y}; V_{sc,y}) \leq \min(N_{sa}; N_{sc})$$

$\alpha = 1$ for anchor channels with

$$\max(V_{sa,y}; V_{sc,y}) > \min(N_{sa}; N_{sc})$$

It shall be permitted to assume reduced values for $V_{sa,y}$ and $V_{sc,y}$ corresponding to the use of an exponent $\alpha = 2$. In this case the reduced values for $V_{sa,y}$ and $V_{sc,y}$ shall also be used in Section 4.2.3.1a).

b) At the point of load application:

$$\left(\frac{N_{ua}^b}{\phi N_{sl}}\right)^\alpha + \left(\frac{V_{ua,y}^b}{\phi V_{sl,y}}\right)^\alpha + \left(\frac{V_{ua,x}^b}{\phi V_{sl,x}}\right)^2 \leq 1.0 \quad (\text{D-32.c})$$

$$\left(\frac{M_{u,flex}}{\phi M_{s,flex}} \right)^\alpha + \left(\frac{V_{ua,y}^b}{\phi V_{sl,y}} \right)^\alpha + \left(\frac{V_{ua,x}^b}{\phi V_{sl,x}} \right)^2 \leq 1.0 \quad (\text{D-32.d})$$

where

$\alpha = 2$ for anchor channels with $V_{sl,y} \leq N_{s,l}$

$\alpha = 1$ for anchor channels with $V_{sl,y} > N_{s,l}$

4.2.6.3 Concrete failure modes of anchor channels under combined loads: For concrete failure modes, anchor channels shall be designed to satisfy the requirements in a) through d).

a) If $\left(\frac{V_{ua,y}^a}{\phi V_{nc,y}} \right) + \left(\frac{V_{ua,x}^a}{\phi V_{nc,x}} \right) \leq 0.2$

then the full strength in tension shall be permitted: $\phi N_{nc} \geq N_{ua}^a$

b) If $N_{ua}^a \leq 0.2\phi N_{nc}$ then the full strength in shear shall be permitted: $\left(\frac{V_{ua,y}^a}{\phi V_{nc,y}} \right) + \left(\frac{V_{ua,x}^a}{\phi V_{nc,x}} \right) \leq 1.0$

c) If $\left(\frac{V_{ua,y}^a}{\phi V_{nc,y}} \right) + \left(\frac{V_{ua,x}^a}{\phi V_{nc,x}} \right) > 0.2$ and $N_{ua}^a > 0.2\phi N_{nc}$

then Eq. (d-32.e) applies

$$\left(\frac{N_{ua}^a}{\phi N_{nc}} \right) + \left(\frac{V_{ua,y}^a}{\phi V_{nc,y}} \right) + \left(\frac{V_{ua,x}^a}{\phi V_{nc,x}} \right) \leq 1.2 \quad (\text{D-32.e})$$

d) Alternatively, instead of satisfying the requirements in a) through c), the interaction Eq. (D-32.f) shall be satisfied:

$$\left(\frac{N_{ua}^a}{\phi N_{nc}} \right)^{5/3} + \left(\frac{V_{ua,y}^a}{\phi V_{nc,y}} \right)^{5/3} + \left(\frac{V_{ua,x}^a}{\phi V_{nc,x}} \right)^{5/3} \leq 1.0 \quad (\text{D-32.f})$$

Where anchors consist of deformed reinforcing bars in accordance with Section 3.1, and the deformed reinforcing bars are lap spliced with reinforcing bars in the member according to the requirements of Section 8.7 of NZS 3101 the interaction equation (D-32.g) shall be satisfied.

$$\left(\frac{V_{ua,y}^a}{\phi V_{nc,y}} \right)^{5/3} + \left(\frac{V_{ua,x}^a}{\phi V_{nc,x}} \right)^{5/3} \leq \alpha \quad (\text{D-32.g})$$

where

$\alpha = 0.9$ for anchor channels with deformed reinforcing bars not debonded

$\alpha = 1.0$ for anchor channels with deformed reinforcing bars debonded underneath the channel profile for a length of 2 in. (50mm).

4.2.7 Minimum member thickness, anchor spacing, and edge distance: Anchor channels shall satisfy the requirements for edge distance, anchor spacing, and member thickness.

The minimum edge distance, minimum and maximum anchor spacing, and minimum member thickness shall be taken from [Table 1](#) of this report.

The critical edge distance, c_{ac} , shall be taken from [Table 4](#) of this report.

4.3 Durability (Clause B2):

4.3.1 General: The anchor channels have an expected life exceeding 50 years when designed, installed and maintained in accordance with this report, and the manufacturer's installation instructions.

Maintenance: Maintenance of the anchor channels installed in interior, dry and protected environments will not normally be required during the expected life of the anchor channels.

4.4 Installation:

Installation parameters are provided in [Table 1](#) of this report. Anchor channel locations shall comply with this report and the plans and specifications approved by the council. Installation of the anchor channels and

channel bolts shall conform to the manufacturer's printed installation instructions (MPII) included in each shipment, as provided in [Table 10](#) and [Figures D](#) and [E](#) of this report.

4.5 Inspection:

Inspections must be performed by an independent qualified person as listed in the building consent and as required by this report. For each type of anchor channel, the manufacturer shall provide inspection procedures to verify proper usage.

4.5.1 Inspection requirements: Prior to concrete placement, the inspector shall inspect the placement of anchor channels in the formwork to verify anchor channel type, channel size, anchor type, number of anchors, anchor size, and length of anchors, as well as anchor channel location, position, orientation and edge distance in accordance with the construction documents. The inspector shall also verify that anchor channels are secured within the formwork in accordance with the manufacturer's printed installation instructions (MPII).

Following placement of concrete and form removal, the inspector shall verify that the concrete around the anchor channel is without significant visual defects, that the anchor channel is flush with the concrete surface, and that the channel interior is free of concrete, laitance, or other obstructions. When anchor channels are not flush with the concrete surface, the inspector shall verify that appropriate sized shims are provided in accordance with the MPII. Following the installation of attachments to the anchor channel, the inspector shall verify that the specified system hardware, such as T-headed channel bolts and washers, have been used and positioned correctly, and the installation torque has been applied to the channel bolts in accordance with the installation instructions (MPII).

The inspector shall be present for the installations of attachments to each type and size of anchor channel.

Where they exceed the requirements stated here, the inspector shall adhere to the inspection requirements provided in the construction documents as prepared by the designer and the required inspections listed in the building consent.

4.5.2 Proof loading program: Where required by the designer, a program for on-site proof loading (proof loading program) to be conducted as part of the special inspection shall include at a minimum the following information:

1. Frequency and location of proof loading based on channel size and length;
2. Proof loads specified by channel size and channel bolt;
3. Acceptable displacements at proof load;
4. Remedial action in the event of failure to achieve proof load or excessive displacement.

5.0 CONDITIONS OF USE:

The HALFEN HZA anchor channel and HZS channel bolts described in this report are a suitable alternative to what is specified in those codes listed in Section 1.0 of this report, subject to the following conditions:

- 5.1 The anchor channels and channel bolts are evaluated for use to resist static short- and long-term loads, including wind and seismic loads, subject to the conditions of this report.
- 5.2 The anchor channels and channel bolts shall be installed in accordance with the manufacturer's printed installation instructions (MPII), as included in the shipment and as shown in [Table 10](#) and [Figures D](#) and [E](#) of this report.
- 5.3 The anchor channels shall be installed in cracked or uncracked normal-weight concrete having a specified compressive strength $f_c = 2,900$ psi to 10,000 psi (20.0 MPa to 69.0 MPa).
- 5.4 The use of anchor channels in lightweight concrete is beyond the scope of this evaluation report.
- 5.5 Strength design values shall be established in accordance with Section 4.2 of this report.
- 5.6 Minimum and maximum anchor spacing and minimum edge distance as well as minimum member thickness shall comply with the values given in this report.
- 5.7 Prior to anchor channel installation, calculations and details demonstrating compliance with this report shall be submitted to the council. The calculations and details shall be prepared by a designer where required by the statutes of the jurisdiction in which the project is to be constructed.

- 5.8 Where not otherwise prohibited by the code, HALFEN HZA anchor channels are permitted for use with fire-resistance-rated construction provided that at least one of the following conditions is fulfilled:
- Anchor channels are used to resist wind or seismic forces.
 - Anchor channels that support a fire-resistance-rated envelope or a fire-resistance-rated membrane are protected by approved fire-resistance-rated materials, or have been evaluated for resistance to fire exposure in accordance with recognized standards.
 - Anchor channels are used to support nonstructural elements.
- 5.9 Since an acceptance criteria for evaluating data to determine the performance of anchor channels subjected to fatigue or shock loading is unavailable at this time, the use of these anchor channels under such conditions is beyond the scope of this report.
- 5.10 Use of hot-dip galvanized carbon steel and stainless steel anchor channels in exterior conditions or damp environments has not been evaluated and is the responsibility of the designer.
- 5.11 Steel anchoring materials in contact with preservative-treated and fire-retardant-treated wood has not been evaluated and is outside the scope of this report. Inspection shall be provided in accordance with Section 4.5 of this report.
- 5.12 HALFEN anchor channels and channel bolts are produced under an approved quality-control program with regular inspections performed by ICC-ES.

6.0 EVIDENCE SUBMITTED

- 6.1 Data in accordance with [ICC-ES Acceptance Criteria for Anchor Channels in Concrete Elements \(AC232\)](#), dated October 2019.
- 6.2 Quality control documentation.

7.0 IDENTIFICATION

- 7.1 The ICC-ES mark of conformity, electronic labeling, or the evaluation report number (ICC-ES ESA-2023) along with the name, registered trademark, or registered logo of the report holder must be included in the product label for the anchor channels and the channel bolts.
- 7.2 In addition, the anchor channels are identified by the manufacturer's name, anchor channel type and size (e.g. HZA 53/34) embossed into the channel profile or printed on the channel profile. The marking is visible after installation of the anchor channel. The evaluation report number ESA-2023 and ICC-ES mark will be stated on the accompanying documents.
- 7.3 The channel bolts are identified by packaging labeled with the manufacturer's name, bolt type, bolt diameter and length, bolt grade, corrosion protection type (e.g. HZS 53/34 M16 x 60), evaluation report number (ESA-2023).
- 7.4 The report holder's contact information is as follows:

LEVIAT GMBH
LIEBIGSTRASSE 14
LANGENFELD-RICHRATH, 40764
GERMANY
+492173970-421
www.leviat.com

8.0 NOTATIONS

Equations are provided in units of inches and pounds. For convenience, SI (metric) units are provided in parentheses where appropriate. Unless otherwise noted, values in SI units shall be not used in equations without conversion to units of inches and pounds.

- b_{ch} width of channel, as shown in [Figure A](#), in. (mm)
- c_a edge distance of anchor channel, measured from edge of concrete member to axis of the nearest anchor as shown in [Figure A](#), in. (mm)
- c_{a1} edge distance of anchor channel in direction 1 as shown in [Figure A](#), in. (mm)
- c'_{a1} net distance between edge of the concrete member and the anchor channel: $c'_{a1} = c_{a1} - b_{ch}/2$, in. (mm)
- $c_{a1,red}$ reduced edge distance of the anchor channel, as referenced in Eq. (D-29.c)
- c_{a2} edge distance of anchor channel in direction 2 as shown in [Figure A](#), in. (mm)
- $c_{a,max}$ maximum edge distance of anchor channel, in. (mm)
- $c_{a,min}$ minimum edge distance of anchor channel, in. (mm)
- c_{ac} edge distance required to develop full concrete capacity in absence of reinforcement to control splitting, in. (mm)
- c_{cr} edge distance required to develop full concrete capacity in absence of anchor reinforcement, in. (mm)
- $c_{cr,N}$ critical edge distance for anchor channel for tension loading for concrete breakout, in. (mm)
- $c_{cr,Nb}$ critical edge distance for anchor channel for tension loading, concrete blow out, in. (mm)
- $c_{cr,V}$ critical edge distance for anchor channel for shear loading, concrete edge breakout, in. (mm)
- c_{nom} nominal concrete cover according to code, in. (mm)
- d_1 width of head of I-anchors, as shown in [Figure A](#) of this annex, in. (mm)
- d_a diameter of anchor reinforcement, in. (mm)
- d_s diameter of channel bolt, in. (mm)
- e_1 distance between shear load and concrete surface, in. (mm)
- e_s distance between the axis of the shear load and the axis of the anchor reinforcement resisting the shear load, in. (mm)
- f distance between anchor head and surface of the concrete, in. (mm)
- f'_c specified concrete compressive strength, psi (MPa)
- f_{uta} specified ultimate tensile strength of anchor, psi (MPa)
- f_{utc} specified ultimate tensile strength of channel, psi (MPa)
- f_{utb} specified ultimate tensile strength of channel bolt, psi (MPa)
- f_y specified yield tensile strength of steel, psi (MPa)
- f_{ya} specified yield strength of anchor, psi (MPa)
- f_{yc} specified yield strength of channel, psi (MPa)
- f_{yb} specified yield strength of channel bolt, psi (MPa)
- h thickness of concrete member, as shown in [Figure A](#), in. (mm)
- h_{ch} height of channel, as shown in [Figure A](#), in. (mm)
- $h_{cr,V}$ critical member thickness, in. (mm)
- h_{ef} effective embedment depth, as shown in [Figure A](#), in. (mm)
- k load distribution factor, as referenced in Eq. (D-0.a)
- k_{cp} pryout factor
- l lever arm of the shear force acting on the channel bolt, in. (mm)

ℓ_{in}	influence length of an external load N_{ua} along an anchor channel, in. (mm)
ℓ_{dh}	development length in tension of deformed bar or deformed wire with a standard hook, measured from critical section to outside end of hook, in. (mm)
ℓ_R	length of deformed bar, in. (mm)
n_{ch}	number of adjacent anchor channels
n_1	number of anchor rows in direction 1 perpendicular to the edge
ρ	web thickness of I-anchor, as shown in Figure B , in. (mm)
s	spacing of anchors in direction of longitudinal axis of channel, in. (mm)
S_{chb}	center-to-center distance between two channel bolts in direction of longitudinal axis of channel, in. (mm)
$S_{ch,x}$	center-to-center spacing of adjacent end anchors of anchor channels in linear configuration, in. (mm)
$S_{ch,y}$	axis-to-axis spacing of two anchor channels in parallel configuration, in. (mm)
S_{cr}	anchor spacing required to develop full concrete capacity in absence of anchor reinforcement, in. (mm)
$S_{cr,N}$	critical anchor spacing for tension loading, concrete breakout, in. (mm)
S_{max}	maximum spacing of anchors of anchor channel, in. (mm)
S_{min}	minimum spacing of anchors of anchor channel, in. (mm)
$S_{cr,Nb}$	critical anchor spacing for tension loading, concrete blow-out, in. (mm)
$S_{cr,V}$	critical anchor spacing for shear loading, concrete edge breakout, in. (mm)
w_A	width of I-shaped anchor, as shown in Figure A , in. (mm)
x	distance between end of channel and nearest anchor, in. (mm)
z	internal lever arm of the concrete member, in. (mm)
A_{brg}	bearing area of anchor head, in. ² (mm ²)
A_i	ordinate at the position of the anchor i , as illustrated in Figure 2 , in. (mm)
$A_{se,N}$	effective cross-sectional area of anchor or channel bolt in tension, in. ² (mm ²)
$A_{se,V}$	effective cross-sectional area of channel bolt in shear, in. ² (mm ²)
I_y	moment of inertia of the channel about principal y -axis, in. ⁴ (mm ⁴)
M_1	bending moment on fixture around axis in direction 1, lbf-in. (Nm)
M_2	bending moment on fixture around axis in direction 2, lbf-in. (Nm)
$M_{s,flex}$	nominal flexural strength of the anchor channel, lbf-in. (Nm)
$M_{s,flex,allowable,ASD}$	allowable bending moment due to tension loads for use in allowable stress design environments, lbf-in. (Nm)
M_{ss}	flexural strength of the channel bolt, lbf-in. (Nm)
M_{ss}^0	nominal flexural strength of the channel bolt, lbf-in. (Nm)
$M_{u,flex}$	bending moment on the channel due to tension loads, lbf-in. (Nm)
N_b	basic concrete breakout strength of a single anchor in tension, lbf (N)
N_{ca}	nominal strength of anchor reinforcement to take up tension loads, lbf (N)
N_{cb}	concrete breakout strength of a single anchor of anchor channel in tension, lbf (N)
N_n	lowest nominal tension strength of an anchor from all appropriate failure modes under tension, lbf (N)
N_p	pullout strength of a single anchor of an anchor channel in tension, lbf (N)
N_{pn}	nominal pullout strength of a single anchor of an anchor channel in tension, lbf (N)
N_{nc}	nominal tension strength of one anchor from all concrete failure modes (lowest value of N_{cb} (anchor channels without anchor reinforcement to take up tension loads) or N_{ca} (anchor channels with anchor reinforcement to take up tension loads), N_{pn} , and N_{sb}), lbf (N)

- N_{ns} nominal steel strength of anchor channel loaded in tension (lowest value of N_{sa} , N_{sc} and N_{sl}), lbf (N)
- $N_{ns,a}$ nominal tension strength for steel failure of anchor or connection between anchor and channel (lowest value of N_{sa} and N_{sc}), lbf (N)
- N_{sa} nominal tensile steel strength of a single anchor, lbf (N)
- N_{sc} nominal tensile steel strength of the connection between anchor and channel profile, lbf (N)
- N_{sl} nominal tensile steel strength of the local bending of the channel lips, lbf (N)
- N_{ss} nominal tensile strength of a channel bolt, lbf (N)
- N_{ua} factored tension load on anchor channel, lbf (N)
- N^a_{ua} factored tension load on a single anchor of the anchor channel, lbf (N)
- $N^b_{ua,i}$ factored tension load on anchor i of the anchor channel, lbf (N)
- N^b_{ua} factored tension load on a channel bolt, lbf (N)
- $N_{ua,re}$ factored tension load acting on the anchor reinforcement, lbf (N)
- $T_{allowable,ASD}$ allowable tension load for use in allowable stress design environments, lbf (N)
- T_{inst} Installation torque moment given in the manufacturer's installation instruction, lbf-ft. (Nm)
- $V_{allowable,ASD}$ allowable shear load for use in allowable stress design environments, lbf (N)
- V_b basic concrete breakout strength in shear of a single anchor, lbf (N)
- $V_{ca,y}$ nominal strength of the anchor reinforcement of one anchor to take up shear loads perpendicular to the channel axis, lbf (N)
- $V_{ca,y,max}$ maximum value of $V_{ca,y}$ of one anchor to be used in design, lbf (N)
- $V_{cb,y}$ nominal concrete breakout strength in shear perpendicular to the channel axis of an anchor channel, lbf (N)
- V_{cp} nominal pryout strength of a single anchor, lbf (N)
- $V_{cp,y}$ nominal pryout strength perpendicular to the channel axis of a single anchor, lbf (N)
- $V_{n,y}$ lowest nominal steel strength from all appropriate failure modes under shear perpendicular to the channel axis, lbf (N)
- V_{nc} nominal shear strength of one anchor from all concrete failure modes (lowest value of V_{cb} (anchor channels with anchor reinforcement to take up shear loads) or V_{ca} (anchor channels with anchor reinforcement to take up shear loads) and V_{cp}), lbf (N)
- V_{ns} nominal steel strength of anchor channel loaded in shear (lowest value of V_{sa} , V_{sc} , and V_{sl}), lbf (N)
- $V_{ns,a}$ nominal shear strength for steel failure of anchor or connection between anchor and channel (lowest value of V_{sa} and V_{sc}), lbf (N)
- $V_{sa,y}$ nominal shear steel strength perpendicular to the channel axis of a single anchor, lbf (N)
- $V_{sc,y}$ nominal shear strength of connection between one anchor bolt and the anchor channel, lbf (N)
- $V_{sl,y}$ nominal shear steel strength perpendicular to the channel axis of the local bending of the channel lips, lbf (N)
- V_{ss} nominal strength of channel bolt in shear, lbf (N)
- $V_{ss,M}$ nominal strength of channel bolt in case of shear with lever arm, lbf (N)
- V_{ua} factored shear load on anchor channel, lbf (N)
- $V_{ua,y}$ factored shear load on anchor channel perpendicular to the channel axis, lbf (N)
- V^a_{ua} factored shear load on a single anchor of the anchor channel, lbf (N)
- $V^a_{ua,y}$ factored shear load on a single anchor of the anchor channel perpendicular to the channel axis, lbf (N)
- $V^a_{ua,i}$ factored shear load on anchor i of the anchor channel, lbf (N)
- $V^a_{ua,y,i}$ factored shear load on anchor i of the anchor channel perpendicular to the channel axis, lbf (N)
- V_{ua} factored shear load on a channel bolt, lbf (N)
- $V^b_{ua,y}$ factored shear load on a channel bolt perpendicular to the channel axis, lbf (N)

- $V_{y,allowable,ASD}$ allowable shear load perpendicular to the channel axis for use in allowable stress design environments, lbf (N)
- α exponent of interaction equation [-]
- α_{ASD} conversion factor for allowable stress design [-]
- $\alpha_{ch,N}$ factor to account for the influence of channel size on concrete breakout strength in tension [-]
- α_M factor to account for the influence of restraint of fixture on the flexural strength of the channel bolt [-]
- $\alpha_{ch,V}$ factor to account for the influence of channel size and anchor diameter on concrete edge breakout strength in shear, (lbf^{1/2}/in.^{1/3}) (N^{1/2}/mm^{1/3})
- $\psi_{c,N}$ modification factor to account for influence of cracked or uncracked concrete on concrete breakout strength [-]
- $\psi_{c,Nb}$ modification factor to account for influence of cracked or uncracked concrete on concrete blowout strength [-]
- $\psi_{c,V}$ modification factor to account for influence of cracked or uncracked concrete for concrete edge breakout strength [-]
- $\psi_{co,N}$ modification factor for corner effects on concrete breakout strength for anchors loaded in tension [-]
- $\psi_{co,Nb}$ modification factor for corner effects on concrete blowout strength for anchors loaded in tension [-]
- $\psi_{co,V}$ modification factor for corner effects on concrete edge breakout strength for anchor channels loaded in shear [-]
- $\psi_{cp,N}$ modification factor for anchor channels to control splitting [-]
- $\psi_{ed,N}$ modification factor for edge effect on concrete breakout strength for anchors loaded in tension [-]
- $\psi_{g,Nb}$ modification factor to account for influence of bearing area of neighboring anchors on concrete blowout strength for anchors loaded in tension [-]
- $\psi_{h,V}$ modification factor to account for influence of member thickness on concrete edge breakout strength for anchors channels loaded in shear [-]
- $\psi_{s,N}$ modification factor to account for influence of location and loading of neighboring anchors on concrete breakout strength for anchor channels loaded in tension [-]
- $\psi_{s,V}$ modification factor to account for influence of location and loading of neighboring anchors on concrete edge breakout strength for anchor channels loaded in shear [-]

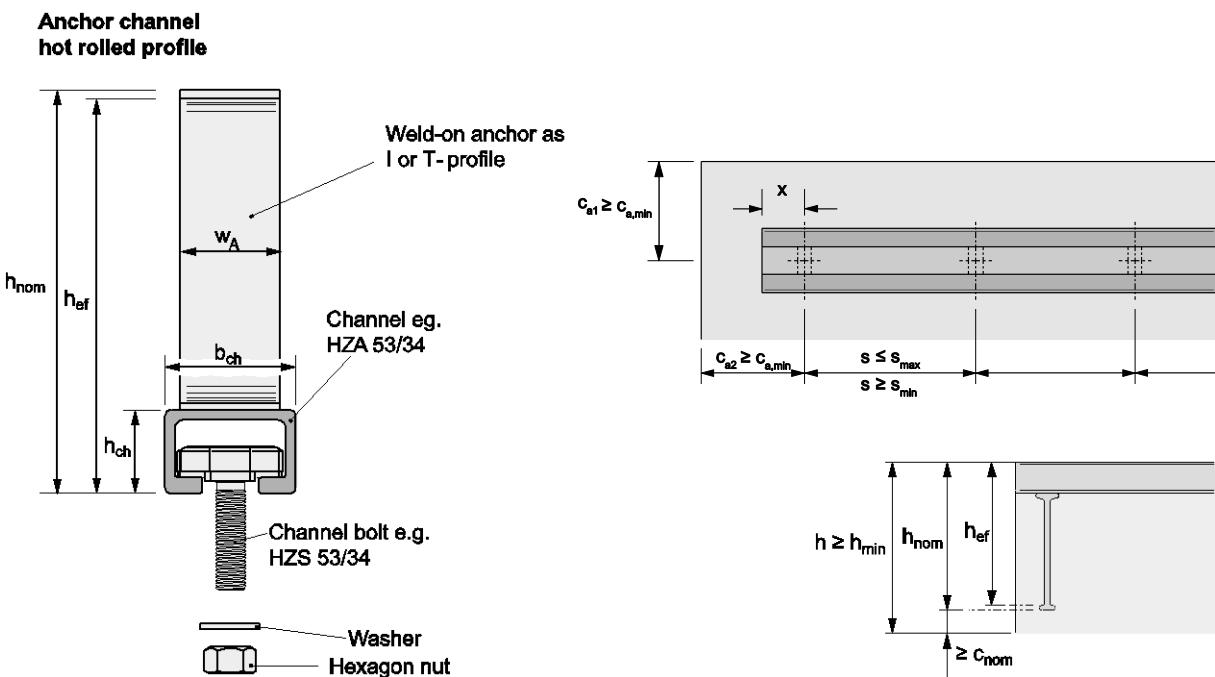

FIGURE A—INSTALLATION PARAMETERS FOR ANCHOR CHANNELS

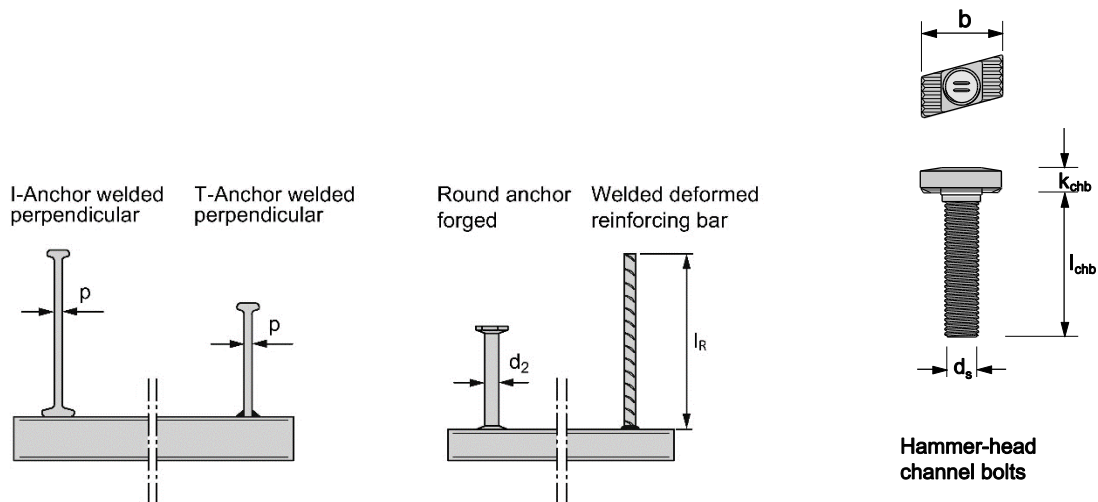

FIGURE B— I- AND T-ANCHORS, ROUND ANCHORS AND DEFORMED REINFORCING BARS FIGURE C—CHANNEL BOLTS

TABLE 1—INSTALLATION PARAMETERS FOR HALFEN HZA ANCHOR CHANNELS

CRITERIA	SYMBOL	UNITS	ANCHOR CHANNEL SIZES			
			41/22 ¹	38/23 ¹	41/27	53/34 ¹
Channel height	h_{ch}	in.	0.81	0.91	1.06	1.34
		(mm)	(20.7)	(23.0)	(27.0)	(34.0)
Channel width	b_{ch}	in.	1.63	1.51	1.57	2.07
		(mm)	(41.3)	(38.0)	(40.0)	(52.5)
Moment of inertia, carbon and stainless steel	I_y	in. ⁴	0.031	0.0507	0.0937	0.2225
		(mm ⁴)	(12,600)	(21,100)	(39,000)	(92,600)
Minimum anchor spacing	s_{min}	in.	1.97	3.94	3.15	3.15
		(mm)	(50)	(100)	(80)	(80)
Minimum anchor spacing, welded reinforcing bar	s_{min}	in.	-	4.00	3.15	4.00
		(mm)	-	(100)	(80)	(100)
Maximum anchor spacing	s_{max}	in.	9.84	9.84	9.84	9.84
		(mm)	(250)	(250)	(250)	(250)
Installation height, round anchor	h_{nom}	in.	3.31	3.79	5.93	6.21
		(mm)	(84)	(96)	(151)	(158)
Installation height, welded I-shaped anchors	h_{nom}	in.	-	5.94	-	6.38
		(mm)	-	(151)	-	(162)
Installation height, welded T-shaped anchors	h_{nom}	in.	-	3.23	-	3.78
		(mm)	-	(82)	-	(96)
Reinforcing bar size	d_b	-	-	#4	#5	#5
Length of deformed reinforcing bar	l_R	in.	-	acc. NZS 3101 Sec. 8.7		
		(mm)	-			
Minimum edge distance	$c_{a,min}$	in.	1.97	2.95	2.95	3.94
		(mm)	(50)	(75)	(75)	(100)
End spacing	x	in.	0.98	0.98	1.38	1.38
		(mm)	(25)	(25)	(35)	(35)
Minimum shaft diameter	d_2	in.	0.31	0.39	0.47	0.47
		(mm)	(8)	(10)	(12)	(12)
Minimum web thickness	p	in.	-	0.24	-	0.24
		(mm)	-	(6.0)	-	(6.0)
Minimum width of welded I- or T-shaped anchors	w_A	in.	-	0.98	-	1.54
		(mm)	-	(25.0)	-	(39.0)
Minimum member thickness, round anchors	h_{min}	in.	4.92	4.92	6.69	7.87
		(mm)	(125)	(125)	(170)	(200)
Minimum member thickness, welded I-shaped anchors	h_{min}	in.	-	7.48	-	7.48
		(mm)	-	(190.0)	-	(190.0)
Minimum member thickness, welded T-shaped anchors	h_{min}	in.	-	4.00	-	4.37
		(mm)	-	(101.5)	-	(111.1)

For SI: 1 in. = 25.4 mm For inch-pound units: 1 mm = 0.03937 in.

¹Carbon and stainless steel, stainless steel anchor channels only applicable to round anchors.

TABLE 2—COMBINATION ANCHOR CHANNEL – CHANNEL BOLTS

CRITERIA	SYMBOL	UNITS	ANCHOR CHANNEL SIZES			
			41/22	38/23	41/27	53/34
Bolt type			HZS 41/22 ¹	HZS 38/23 ¹	HZS 38/23 ¹	HZS 53/34 ¹
Diameter	d_s	(mm)	(12)	(12)	(12)	-
		(mm)	(16)	(16)	(16)	(16)
		(mm)	-	-	-	(20)

For SI: 1 in. = 25.4 mm

For inch-pound units: 1 mm = 0.03937 in.

¹Hammer-head channel bolts

TABLE 3—HZA ANCHOR CHANNELS: STATIC STEEL STRENGTH IN TENSION

CRITERIA	SYMBOL	UNITS	ANCHOR CHANNEL SIZES			
			41/22	38/23	41/27	53/34
Nominal strength for local bending of channel lips in static tension and tension for seismic design	N_{sl} and $N_{sl,seis}$	lbf	4,069	8,840	12,050	17,682
		(kN)	(18.1)	(39.3)	(53.6)	(78.7)
Nominal steel strength of a single anchor in static tension and tension for seismic design, round anchors	N_{sa} and $N_{sa,seis}$	lbf	4,069	8,093	12,050	12,364
		(kN)	(18.1)	(31.4)	(53.6)	(55.0)
Nominal steel strength of a single anchor in static tension and tension for seismic design, welded I- or T-shaped anchors	N_{sa} and $N_{sa,seis}$	lbf	-	12,140	-	18,938
		(kN)	-	(54.0)	-	(84.2)
Nominal steel strength of a single deformed reinforcing bar in static tension and tension for seismic design	N_{sa} and $N_{sa,seis}$	lbf	-	16,000	24,800	24,800
		(kN)	-	(71.2)	(110.3)	(110.3)
Nominal tension strength connection channel / round anchors for static and seismic design	N_{sc} and $N_{sc,seis}$	lbf	4,069	8,093	12,050	12,364
		(kN)	(18.1)	(31.4)	(53.6)	(55.0)
Nominal tension strength connection channel / welded I-or T-shaped anchors for static and seismic design	N_{sc} and $N_{sc,seis}$	lbf	-	8,840	-	17,682
		(kN)	-	(39.3)	-	(78.7)
Nominal tension strength connection channel / deformed reinforced bar for static and seismic design	N_{sc} and $N_{sc,seis}$	lbf	-	7,406	11,279	16,763
		(kN)	-	(32.9)	(50.2)	(74.6)
Strength reduction factor ¹	ϕ	-	0.75			
Nominal bending strength, carbon steel for static and seismic design	$M_{s,flex}$ and $M_{s,flex,seismic}$	lbf-in.	6,488	14,721	20,259	36,241
		(Nm)	(733)	(1,663)	(2,289)	(4,095)
Nominal bending strength, stainless steel for static and seismic design	$M_{s,flex}$ and $M_{s,flex,seismic}$	lbf-in.	6,629	14,781	-	31,933
		(Nm)	(749)	(1,670)	-	(3,608)
Strength reduction factor ¹	ϕ	-	0.85			

For SI: 1 in. = 25.4 mm, 1 lbf = 4.448 N, 1 lbf-in. = 8.85 Nm

¹The tabulated value of ϕ applies when the combinations of actions set out in AS/NZS 1170 for the ultimate limit state are used.

TABLE 4—HZA ANCHOR CHANNELS: STATIC CONCRETE STRENGTH IN TENSION

CRITERIA	SYMBOL	UNITS	ANCHOR CHANNEL SIZES			
			41/22	38/23	41/27	53/34
Effective embedment depth for welded I-shaped anchors ²	h_{ef}	in.	-	5.75	-	6.18
		(mm)	-	(146)	-	(157)
Effective embedment depth for round anchors ²	h_{ef}	in.	3.23	3.70	5.83	6.10
		(mm)	(82)	(94)	(148)	(155)
Minimum Effective embedment depth for welded T-shaped anchors ²	h_{ef}	in.	-	3.03	-	3.58
		(mm)	-	(77)	-	(91)
Area of anchor head, round anchors	A_{brg}	in. ²	0.23	0.37	0.59	0.59
		(mm ²)	(150.8)	(235.6)	(377.8)	(377.8)
Area of anchor head, welded I- or T- shaped anchors	A_{brg}	in. ²	-	0.43	-	0.66
		(mm ²)	-	(275.0)	-	(429.0)
Critical edge distance	c_{ac}	in. (mm)	$c_{ac} = 3 \cdot h_{ef}$			
Strength reduction factor ¹	ϕ	-	0.65			

For SI: 1 in. = 25.4 mm, 1 lbf = 4.448 N

For inch-pound units: 1 mm = 0.03937 in., 1 N = 0.2248 lbf

¹The tabulated value of ϕ applies when the combinations of actions set out in AS/NZS 1170 for the ultimate limit state are used and supplementary reinforcement is not provided.

²Embedment depth value is for design calculation used for round anchor and welded anchor, refer to [Table 1](#) for required, h_{nom} , installation embedment.

TABLE 5—HZA ANCHOR CHANNELS: STATIC STEEL STRENGTH IN SHEAR AND INTERACTION EXPONENTS

CRITERIA	SYMBOL	UNITS	ANCHOR CHANNEL SIZES			
			41/22	38/23	41/27	53/34
Nominal strength of channel lips, perpendicular shear for static and seismic design	$V_{sl,y}$ and $V_{sl,y,seis}$	lbf	5,081	8,840	12,050	17,682
		(kN)	(22.6)	(39.3)	(53.6)	(78.7)
Strength reduction factor	ϕ	-	0.65			
Nominal strength of channel lips, longitudinal shear for static and seismic design	$V_{sl,x}$ and $V_{sl,x,seis}$	lbf	2,720	4,406	5,305	13,256
		(kN)	(12.1)	(19.6)	(23.6)	(59.0)
Strength reduction factor	ϕ	-	0.65			
Nominal steel strength of a single anchor in shear, round anchors for static and seismic design	$V_{sa,y}$ and $V_{sa,y,seis}$	lbf	5,081	8,093	12,050	17,682
		(kN)	(22.6)	(36.0)	(53.6)	(78.7)
Nominal steel strength of a single anchor in shear, welded I- or T-shaped anchors for static and seismic design	$V_{sa,y}$ and $V_{sa,y,seis}$	lbf	-	8,840	-	17,682
		(kN)	-	(39.3)	-	(78.7)
Nominal steel strength of a single reinforcing bar in shear for static and seismic design	$V_{sa,y}$ and $V_{sa,y,seis}$	lbf	-	7,406	14,881	16,763
		(kN)	-	(32.9)	(66.2)	(74.6)
Nominal steel strength of a single anchor in shear, round anchors for static and seismic design	$V_{sa,x}$ and $V_{sa,x,seis}$	lbf	2,450	4,226	7,194	7,419
		(kN)	(10.9)	(18.8)	(32.0)	(33.0)
Nominal steel strength of a single anchor in shear, welded I- or T-shaped anchors for static and seismic design	$V_{sa,x}$ and $V_{sa,x,seis}$	lbf	-	7,284	-	11,363
		(kN)	-	(32.4)	-	(50.5)
Nominal steel strength of a single reinforcing bar in shear for static and seismic design	$V_{sa,x}$ and $V_{sa,x,seis}$	lbf	-	9,600	14,881	14,881
		(kN)	-	(42.7)	(66.2)	(66.2)
Nominal shear strength for connection channel / round anchors for static and seismic design	$V_{sc,y}$ and $V_{sc,y,seis}$	lbf	5,081	8,840	12,050	17,682
		(kN)	(22.6)	(39.3)	(53.6)	(78.7)
Nominal shear strength for connection channel / welded I- or T-shaped anchors for static and seismic design	$V_{sc,y}$ and $V_{sc,y,seis}$	lbf	-	8,840	-	17,682
		(kN)	-	(39.3)	-	(78.7)
Nominal shear strength for connection channel / reinforcing bar for static and seismic design	$V_{sc,y}$ and $V_{sc,y,seis}$	lbf	-	7,406	11,279	16,763
		(kN)	-	(32.9)	(50.2)	(74.6)
Nominal shear strength for connection channel / round anchors for static and seismic design	$V_{sc,x}$ and $V_{sc,x,seis}$	lbf	2,450	4,226	7,194	7,419
		(kN)	(10.9)	(18.8)	(32.0)	(33.0)
Nominal shear strength for connection channel / welded I- or T-shaped anchors for static and seismic design	$V_{sc,x}$ and $V_{sc,x,seis}$	lbf	-	5,304	-	10,609
		(kN)	-	(23.6)	-	(47.2)
Nominal shear strength for connection channel / reinforcing bar for static and seismic design	$V_{sc,x}$ and $V_{sc,x,seis}$	lbf	-	4,444	6,767	10,058
		(kN)	-	(19.8)	(30.1)	(44.7)
Strength reduction factor ¹	ϕ	-	0.65			

For SI: 1 in. = 25.4 mm, 1 lbf = 4.448 N

For inch-pound units: 1 mm = 0.03937 in., 1 N = 0.2248 lbf

¹The tabulated value of ϕ applies when the combinations of actions set out in AS/NZS 1170 for the ultimate limit state are used.

TABLE 6—HZA ANCHOR CHANNELS: STATIC CONCRETE STRENGTH IN SHEAR

CRITERIA	SYMBOL	UNITS	ANCHOR CHANNEL SIZES			
			41/22	38/23	41/27	53/34
Cracked concrete without reinforcement	$\alpha_{ch,V}$	$\text{lbf}^{1/2}/\text{in.}^{1/3}$	9.0	10.5	10.5	10.5
		$(\text{N}^{1/2}/\text{mm}^{1/3})$	(6.5)	(7.5)	(7.5)	(7.5)
Pryout failure, factor	k_{cp}	-	2.0			
Strength reduction factor	ϕ	-	0.65			

TABLE 7—HZS CHANNEL BOLTS: STATIC STEEL STRENGTH IN TENSION

CRITERIA	SYMBOL	UNITS	GRADE/MATERIAL	ANCHOR CHANNEL SIZES	CHANNEL BOLT SIZES		
					M12	M16	M20
Nominal tensile strength for static and seismic design	N_{ss} and $N_{ss,seis}$	lbf (kN)	8.8	41/22	10,903	21,649	-
					(48.5)	(96.3)	-
				38/23	15,161	28,236	-
					(67.4)	(125.6)	-
			41/27	15,161	28,236	-	
				(67.4)	(125.6)	-	
			53/34	-	28,236	44,063	
				-	(125.6)	(196.0)	
			Stainless steel grade 50	41/22	9,060	14,388	-
					(40.3)	(64)	-
					-	-	-
			38/23	-	-	-	
-	-	-					
53/34	-	-	-				
	-	-	-				
Stainless steel grade 70	41/22	-	-	-			
		-	-	-			
	38/23	13,264	24,707	-			
(59.0)		(109.9)	-				
53/34	-	24,707	38,555				
	-	(109.9)	(171.5)				
Strength reduction factor	ϕ^1	-	8.8	-	0.65		
			Stainless steel grade 50		0.75		
			Stainless steel grade 70		0.65		

For SI: 1 lbf = 4.448 N

For inch-pound units: 1 N = 0.2248 lbf

¹The tabulated value of ϕ applies when the combinations of actions set out in AS/NZS 1170 for the ultimate limit state are used.

TABLE 8—HZS CHANNEL BOLTS: STATIC STEEL STRENGTH IN SHEAR

CRITERIA	SYMBOL	UNITS	GRADE/MATERIAL	CHANNEL BOLT SIZES		
				M12	M16	M20
Nominal shear strength for static and seismic design	V_{ss} and $V_{ss,seis}$	lbf (kN)	8.8	9,097	16,942	26,438
				(40.5)	(75.4)	(117.6)
			Stainless steel grade 50	5,692	10,589	-
				(25.3)	(47.1)	-
Stainless steel grade 70	7,958	14,815	23,133			
	(35.4)	(65.9)	(102.9)			
Strength reduction factor for steel failure under shear	ϕ^1	-	8.8	0.60		
			Stainless steel grade 50	0.65		
			Stainless steel grade 70	0.60		
Nominal bending strength for static and seismic design	M_{ss} and $M_{ss,seis}$	lbf-in. (Nm)	8.8	938	2,363	4,587
				(106.0)	(267.0)	(518.2)
			Stainless steel grade 50	579	1,478	-
				(65.4)	(167)	-
Stainless steel grade 70	811	2,065	4,025			
	(91.6)	(233.3)	(454.7)			
Strength reduction factor for bending failure	ϕ^1	-	8.8	0.65		
			Stainless steel grade 50	0.75		
			Stainless steel grade 70	0.65		

For SI: 1 in. = 25.4 mm, 1 lbf = 4.448 N

For inch-pound units: 1 mm = 0.03937 in., 1 N = 0.2248 lbf, 1 Nm = 0.113 lbf-in.

¹The tabulated value of ϕ applies when the combinations of actions set out in AS/NZS 1170 for the ultimate limit state are used.

TABLE 9—HZA ANCHOR CHANNELS AND HZS CHANNEL BOLTS: MATERIAL SPECIFICATION AND PROPERTIES

COMPONENT	CARBON STEEL		STAINLESS STEEL
	Material / Strength Class	Coating	Material / Strength Class
Channel profile	Carbon steel	Hot-dip galvanized ≥ 55 μm	Stainless steel A4
Anchor	Carbon steel	Hot-dip galvanized ≥ 55 μm	Stainless steel A4
Reinforcing bar	Low-alloy steel according to ASTM A705 or carbon steel according to DIN 488-BSt 500	-	-
Channel bolts	Carbon steel grade 8.8 according to EN ISO 898-1	Hot-dip galvanized ≥ 50 μm or electroplated ≥ 12 μm	Stainless steel grade 50 and 70 according to EN ISO 3506-1
Plain washer ¹ ISO 7089 and ISO 7093-1	Production class A, 200 HV	Hot-dip galvanized or electroplated	Production class A, 200 HV according to EN ISO 3506-1
Hexagonal nuts ISO 4032	Property class 8 according to EN ISO 898-2	Hot-dip galvanized ≥ 50 μm or electroplated ≥ 12 μm	Stainless steel grade 70 and 80 according to EN ISO 3506-2

¹Not supplied by Leviat

TABLE 10—HZS CHANNEL BOLTS: INSTALLATION TORQUES

CRITERIA	SYMBOL	UNITS	POSITION OF FIXTURE	GRADE/MATERIAL	ANCHOR CHANNEL SIZES	CHANNEL BOLT SIZES		
						M12	M16	M20
Installation torque	T_{inst}^1	lbf-ft. (Nm)	General Fig. E (4.1)	Steel 8.8	41/22	22	30	-
						(30)	(40)	-
					38/23	52	69	-
						(70)	(94)	-
					41/27	(52)	95	-
						(70)	(129)	-
				53/34	-	136	173	
						(185)	(235)	
				Stainless steel grade 50/70	41/22	15	37	-
						(20)	(50)	-
					38/23	39	69	-
						(50)	(75)	-
			53/34			96	122	
						(130)	(165)	
			Steel to steel contact Fig. E (4.2 or 4.3)	Steel 8.8	41/22	37	103	-
						(50)	(140)	-
					38/23	52	136	-
						(70)	(185)	-
					41/27	52	136	-
						(70)	(185)	-
				53/34	-	136	266	
						(185)	(360)	
				Stainless steel grade 50/70	41/22	15	37	-
						(20)	(50)	-
38/23	39	96			-			
	(50)	(130)			-			
53/34	-	96	184					
		(130)	(250)					

For SI: 1 lbf-ft. = 1.3558 Nm

¹ T_{inst} must not be exceeded

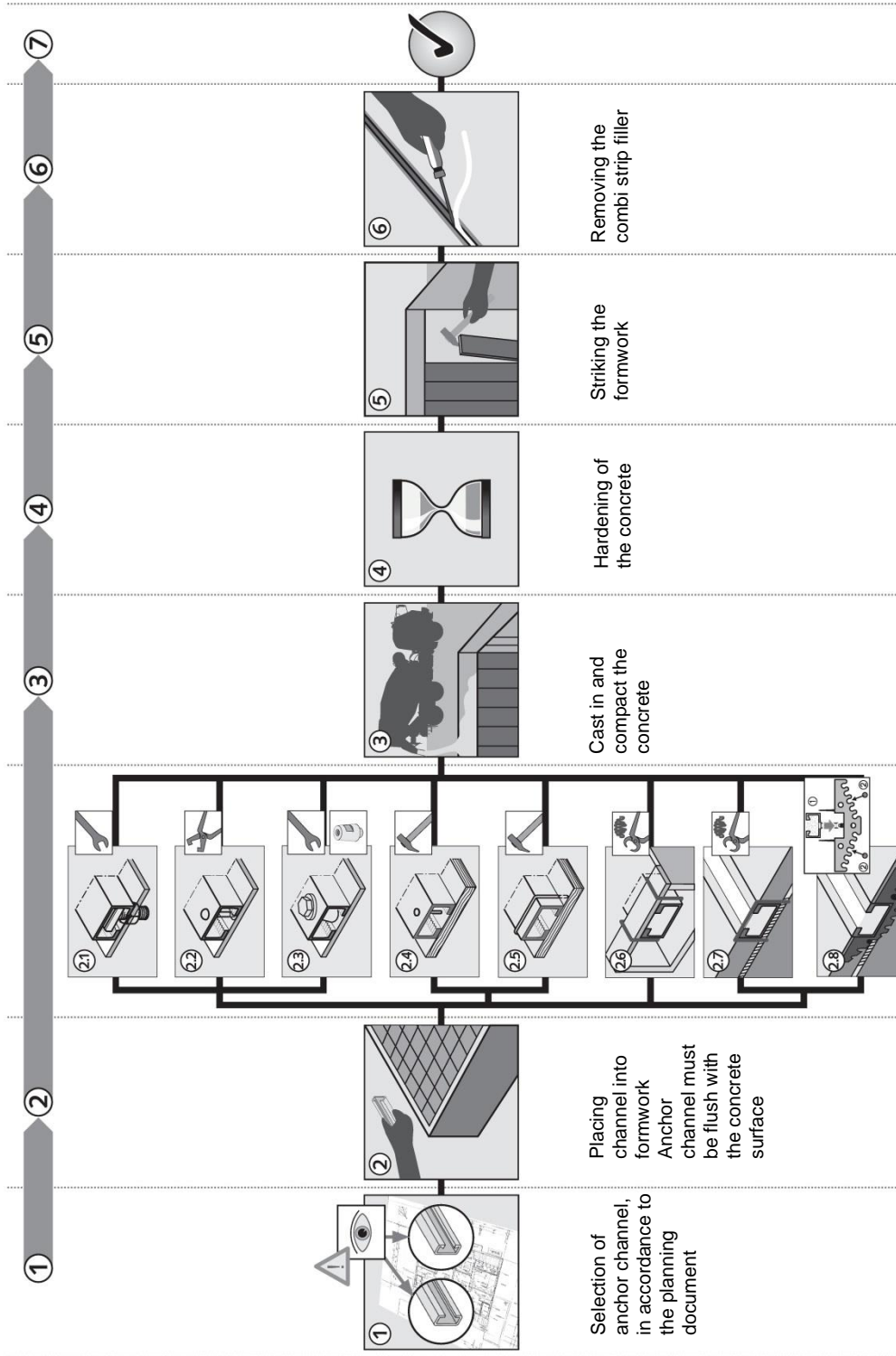

- 2.1 Steel formwork: Fixing with HALFEN channel bolts through formwork penetration
- 2.2 Steel formwork: Fixing with rivets
- 2.3 Steel formwork: Fixing with HALFEN fixing cone
- 2.4 Timber formwork: Fixing with nails
- 2.5 Timber formwork: Fixing with staples
- 2.6 Fixing in the top surface of concrete: Fixing by using auxiliary construction
- 2.7 Fixing in the top surface of concrete: Fixing from above directly to the reinforcement
- 2.8 Fixing in the top surface of concrete: Fixing to the reinforcement, using the HALFEN ChanClip

FIGURE D—HZA ANCHOR CHANNELS: INSTALLATION INSTRUCTIONS

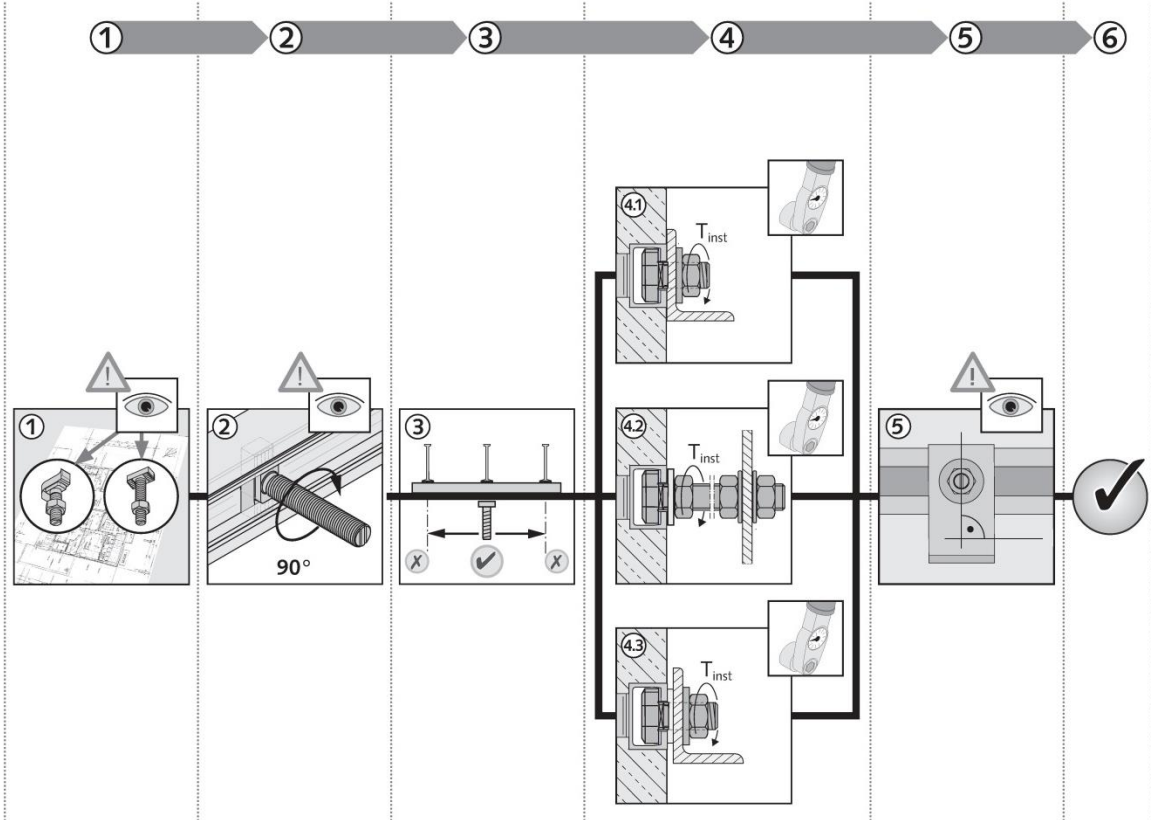

Selection of the HALFEN channel bolts in accordance with the planning document.

Insert the channel bolt into the channel. After a 90° turn clockwise, the channel bolt locks into the channel. (Check of the position of the bolt by notch).

Positioning of the channel bolt: At the channel ends a minimum clearance must be maintained, which corresponds with the overhang beyond the last anchor.

Tighten the hexagonal nut to the setting torque (T_{inst}) acc. table stated below. T_{inst} must not be exceeded.
 4.1: general
 4.2 and 4.3: steel to steel contact.

After fixing the nuts, check the correct position of the bolt: If the notch is not perpendicular to the channel length axis, the channel bolt must be released completely, inserted and tightened again.

FIGURE E—HZS CHANNEL BOLTS: INSTALLATION INSTRUCTIONS